



User Manual

Full HD WDR Day & Night Outdoor Dome Network Camera

Preface

D-Link reserves the right to revise this publication and to make changes in the content hereof without obligation to notify any person or organization of such revisions or changes. Information in this document may become obsolete as our services and websites develop and change.

Manual Revisions

Revision	Date	Description
1.0	03/07/2013	DCS-6513 Revision A1 with firmware version 1.00

Trademarks

D-Link and the D-Link logo are trademarks or registered trademarks of D-Link Corporation or its subsidiaries in the United States or other countries. All other company or product names mentioned herein are trademarks or registered trademarks of their respective companies.

Copyright © 2013 D-Link Corporation.

All rights reserved. This publication may not be reproduced, in whole or in part, without prior expressed written permission from D-Link Corporation.

Table of Contents

Product Overview.....	4	Dynamic DNS.....	43
Package Contents.....	4	Image Setup.....	44
Introduction.....	5	Audio and Video.....	46
System Requirements.....	5	Lens Control.....	48
Features.....	6	Preset.....	49
Hardware Overview.....	7	Motion Detection.....	51
Front.....	7	Time and Date.....	52
Cable Harness.....	8	Event Setup.....	53
Internal.....	9	SD Card.....	61
Assembly and Installation.....	10	Advanced.....	62
Concealed Cable Installation.....	10	Digital Input/Output.....	62
Exposed Cable Installation.....	12	ICR and IR.....	63
Pendant Mount (Optional).....	15	HTTPS.....	64
Bent Mount (Optional).....	18	Access List.....	65
Installation of Weather Shield.....	21	Maintenance.....	66
Adjusting the lens 3-axis angle.....	25	Device Management.....	66
Software Installation.....	26	System.....	67
D-ViewCam Setup Wizard.....	29	Firmware Upgrade.....	68
Configuration.....	31	Status.....	69
Using the Configuration Interface.....	31	Device Info.....	69
Live Video.....	32	Logs.....	70
Setup.....	34	Help.....	71
Setup Wizard.....	34	DI/DO Specifications.....	72
Network Setup.....	40	Technical Specifications.....	73

Product Overview

Package Contents



DCS-6513 Full HD WDR Day & Night Outdoor Dome Network Camera



Power adapter



CD-ROM with User Manual and software



Extension Adapter



Security Wrench



Weather Shield



37mm Screws for Weather Shield



Cable Cover



Rubber Plug



Quick Installation Guide

If any of the above items are missing, please contact your reseller.

Note: Using a power supply with a different voltage than the one included with your product will cause damage and void the warranty for this product.

Introduction

The DCS-6513 Full HD WDR Day & Night Outdoor Dome Network Camera is a professional, vandal-resistant surveillance and security solution for small, medium, and large enterprises alike. The DCS-6513 uses a 3 megapixel progressive scan CMOS sensor; which results in low noise and high sensitivity with Wide Dynamic Range (WRD) capabilities ideal for surveillance applications.

The DCS-6513 is equipped with a P-iris lens that controls the iris with extreme precision. The built-in stepping motor maintains the iris opening at an optimal level at all times, resulting in superior image clarity, depth of field, and image quality. Together with WDR enhancement, users can identify image details in extreme bright, as well as dark environments.

The DCS-6513 has an IP67 certified weatherproof housing designed for both indoor and outdoor applications. The built-in removable IR-cut filter and IR LEDs gives the DCS-6513 the capability to view up to 20M at night. The DCS-6513 also incorporates Power over Ethernet (PoE), allowing it to be easily installed in a variety of locations without the need for supplemental power cabling. The combination of IP67 housing, IR-Cut Filter, IR LEDs and PoE make the DCS-6513 an ideal solution for a high performance, reliable and cost-effective 24 hour HD surveillance solution with an easy, clutter-free installation.

System Requirements

- Computer with Microsoft Windows 8, Windows® 7, Vista®, or XP (for CD-ROM Setup Wizard), Mac OS or Linux
- PC with 1.3GHz or above; at least 128MB RAM
- Internet Explorer 7 or above , Firefox 3.5 or above, Safari 4 and Chrome 8.0 or above
- Existing 10/100 Ethernet-based network
- An Micro SD memory card (optional) is required for recording to onboard storage. SDHC Class 6 or above is recommended.
- Broadband Internet connection

Features

P-iris

The P-iris lens in the DCS-6513 solves the long-standing problem of capturing sharp images in varying light conditions. The DCS-6513 optimizes the iris opening under all lighting conditions, resulting in images with better clarity, resolution and depth of field as well as improved image sharpness and increased image usability for network video surveillance.

Remote Zoom & Focus

The remote focus function eliminates the need for manual focusing at the camera position and allowing the user to make key adjustments from any computer. The remote zoom functionality allows the user to make final adjustments to the zoom from the computer. It provides a convenient way to ensure that the viewing angle is optimized for the scene and required need for resolution.

Wide Dynamic Range

Wide Dynamic Range technology neutralizes imperfect lighting, providing clear images with the right amount of contrast even when a subject is backlit

Automatic Thermostat Temperature Regulation

The DCS-6513 monitors and automatically regulates its temperature to ensure optimal performance even in extreme conditions. It balances fan use against a built in heater based on a range of preset thermostatic settings. This gives the DCS-6513 the ability to perform in the most demanding of environments.

Remote Monitoring Utility

The D-ViewCam application adds enhanced features and functionality for the Network Camera and allows administrators to configure and access the Network Camera from a remote site via Intranet or Internet. Other features include image monitoring, recording images to a hard drive, viewing up to 32 cameras on one screen, and taking snapshots.

IR LED for Day and Night Functionality

The built-in infrared LEDs enables night time viewing of up to 20 meters (65.6 feet).

Robust Weatherproof and Vandal-resistant Housing

The DCS-6513 housing is compliant with both the IP67 weatherproof and IK-10 vandal-resistant certifications, allowing you to rest assured that it will continue to provide round-the-clock surveillance in the toughest of conditions and locations.

PoE (Power over Ethernet) for Flexible Installation

The DCS-6513 can draw all the power it needs from a PoE switch or PoE injector, negating the need for a separate power installation.

Hardware Overview Front



1	Camera Lens	Vari-focal lens to record video of the surrounding area
2	Light Sensor	The light sensor measures the lighting conditions and switches between color and infrared accordingly
3	IR LEDs	Infrared LEDs illuminate the camera's field of view at night
4	Power/Status LED	Indicates the camera's current status
5	Protective Casing	The camera is housed in an IP67 certified weatherproof casing, which protects it against rain and dust. This case is also IK-10 certified vandal-resistant.

Cable Harness

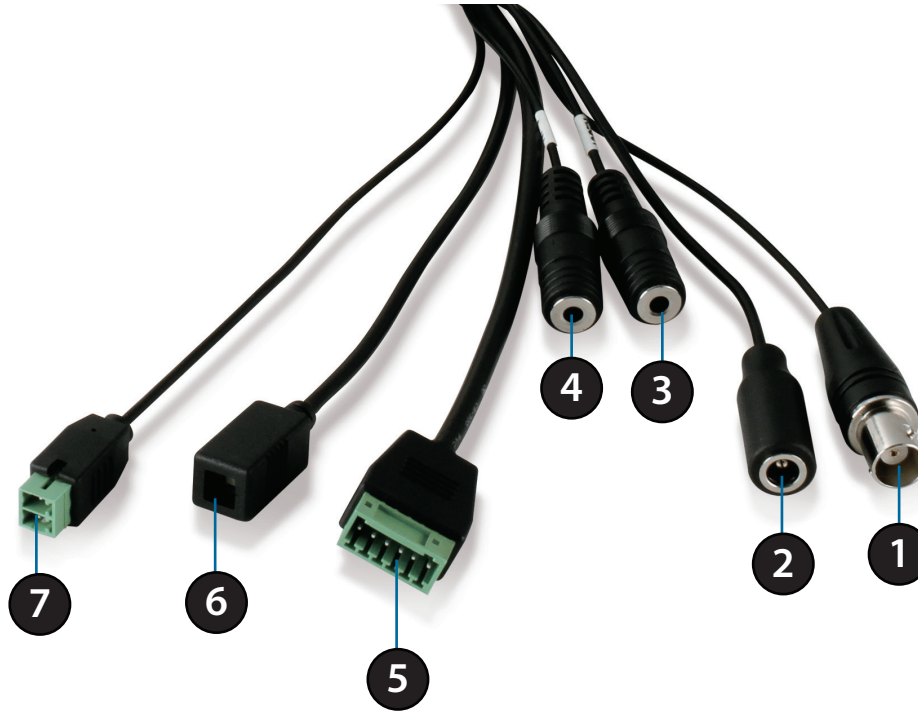

1	BNC Connector	The BNC connector is recommended for use with handheld monitors to check the Field of View during installation.
2	Power Connector	Power connector for the provided 12V DC power adapter.
3	Audio In (A.In)	Connects to a microphone.
4	Audio Out (A.Out)	Connects to a speaker.
5	DI/DO Connector	I/O connectors for external devices. 12V DC output.
6	Reset Button	Press and hold the recessed button for 10 seconds to reset the camera.
7	24 V Power Connector	Connects to 24 V AC power supply.

Internal

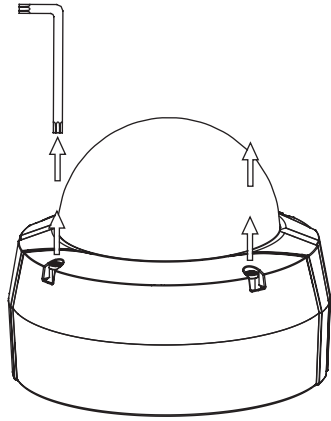

Disassemble the Camera

Open the camera enclosure by loosening the 4 screws. Lift the dome off the base of the camera.

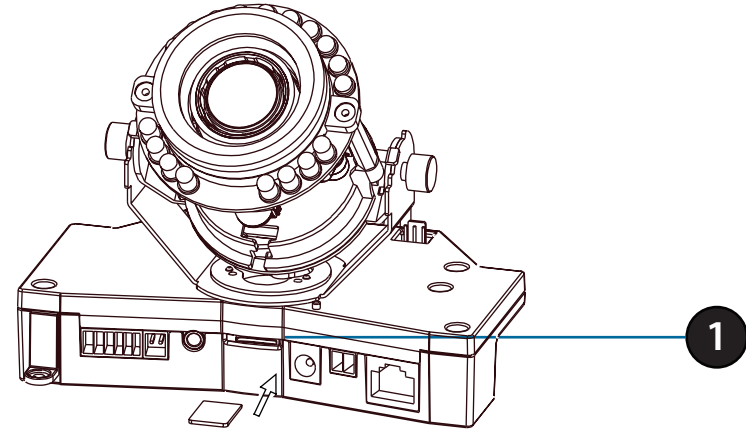

Install the Micro SD Card

Push the Micro SD card into the camera with the gold contacts oriented towards the base of the camera. To eject the Micro SD card, push the Micro SD card into the slot.

1	Micro SD Card Slot	Insert an Micro SD card for local storage of recorded image and video
---	---------------------------	---

Assembly and Installation

Standard Mounting Instructions

Concealed Cable Installation

- Height: 23 mm (0.9 inches)
- Diameter: 183 mm (7.2 inches)
- Weight: 400 g (0.9 lbs)

1. Disassemble the camera enclosure (see page 9).
2. Thread the cables through the waterproof plugs at the bottom of the base of the camera. Attach the cables to the corresponding cable connectors.
3. Locate a suitable position on the ceiling for the mounting plate to be installed.
4. Use the mounting template to mark the holes for installation.
5. Cut an access hole in the ceiling for the cables.
6. Drill four separate 6mm holes corresponding to the holes in the mounting template and insert the plastic anchors into these holes.
7. Attach the surface bracket to the ceiling using the screws provided

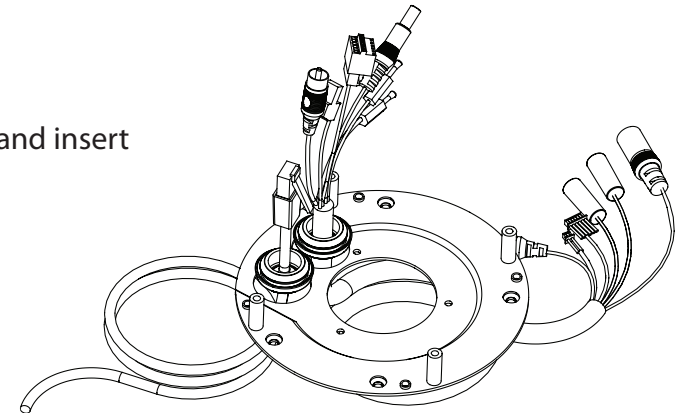
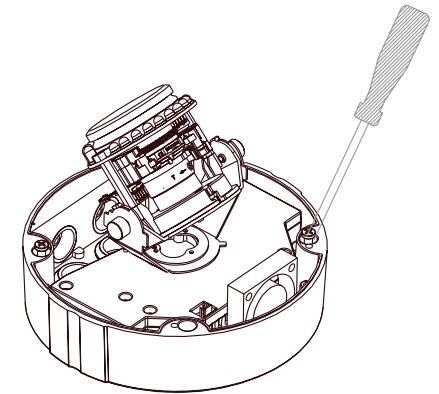

1. Connect the Ethernet cable and the power cable, threading them through the hole in the ceiling.
2. Push the dome body up over the base of the camera.
3. Attach the dome to the base of the camera using the three long screws and the provided security screw.

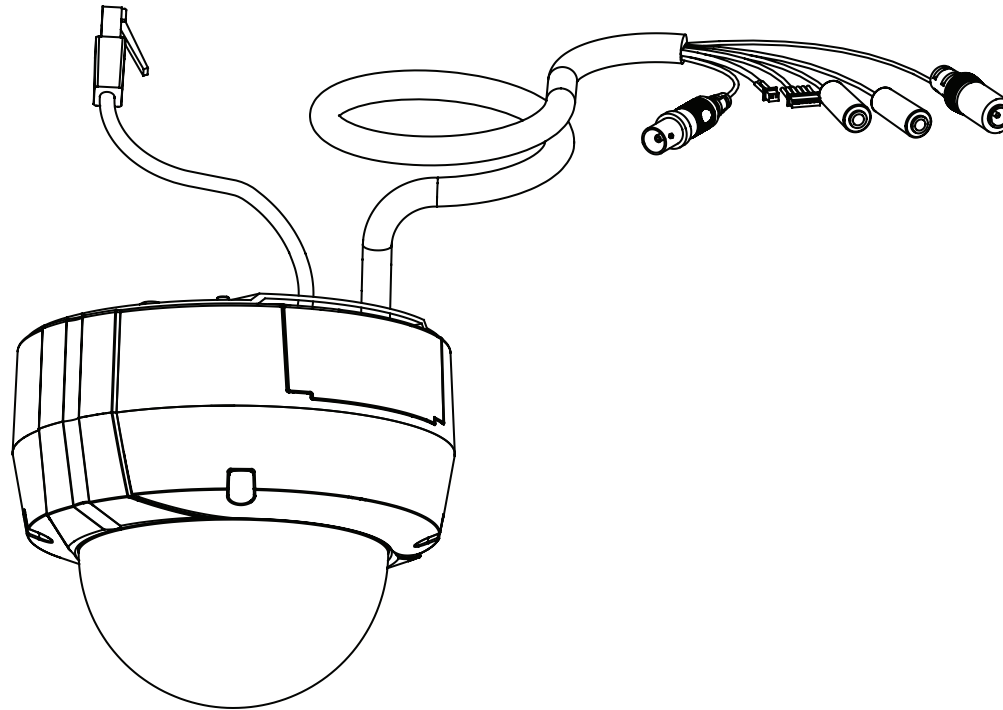

Exposed Cable Installation

- Height: 23 mm (0.9 inches)
- Diameter: 183 mm (7.2 inches)
- Weight: 400 g (0.9 lbs)

1. Disassemble the camera enclosure (see page 9).
2. Remove the small screw to release the faceplate on the side of the base of the camera

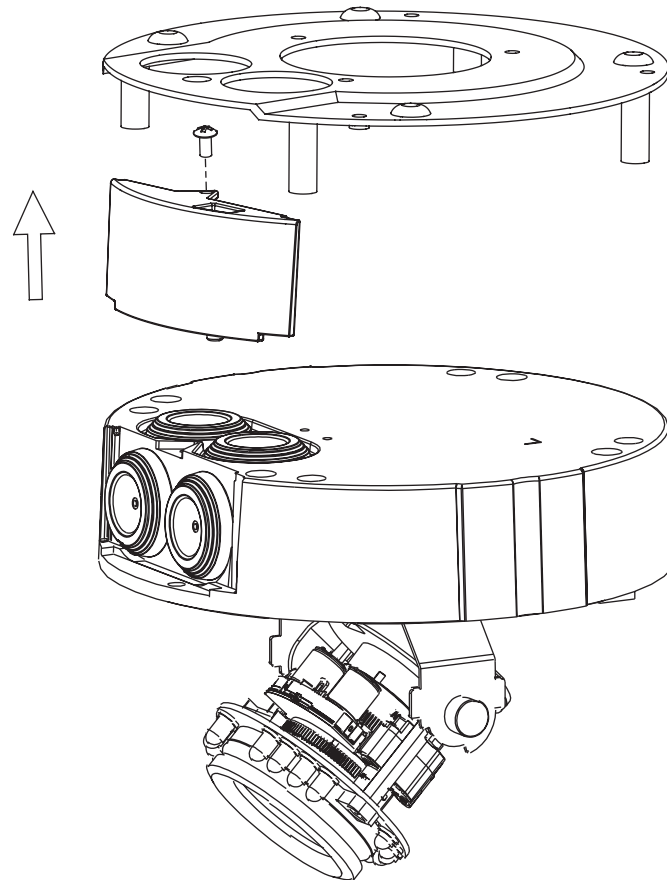

1. Attach the dual-holed plate to the base of the camera
2. Thread the cables through the waterproof plugs on the side of the base of the camera. Attach the cables to the corresponding cable connectors.
3. Place the plastic cable cover onto the dual-holed plate and attach it using the screw.

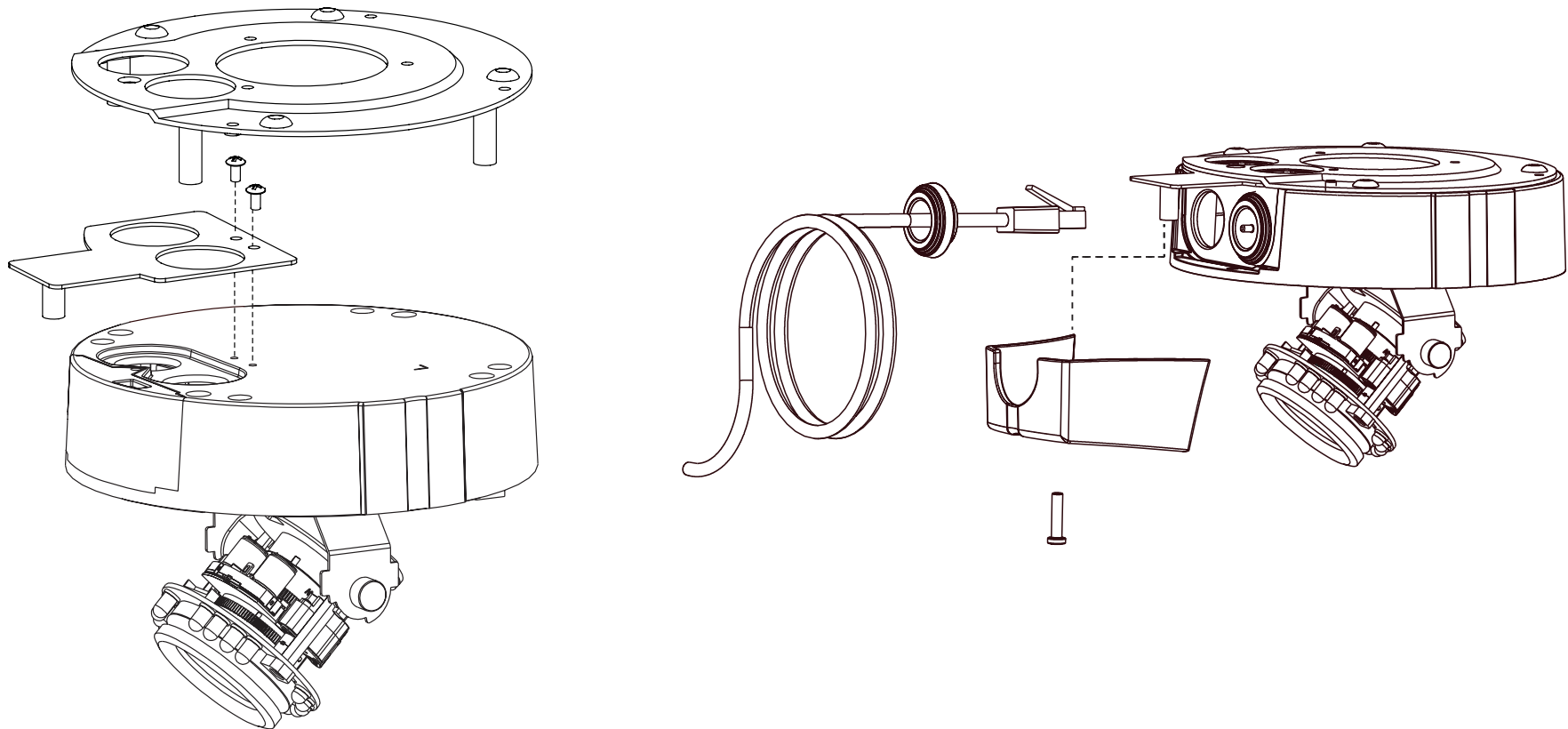

1. Locate a suitable position on the ceiling for the mounting plate to be installed.
2. Use the mounting template to mark the holes for installation.
3. Drill four separate 6mm holes corresponding to the holes in the mounting template and insert the plastic anchors into these holes.
4. Attach the surface bracket to the ceiling using the screws provided.
5. Place the dome body onto the base of the camera.
6. Attach the dome to the base of the camera using the three long screws and the provided security screw.

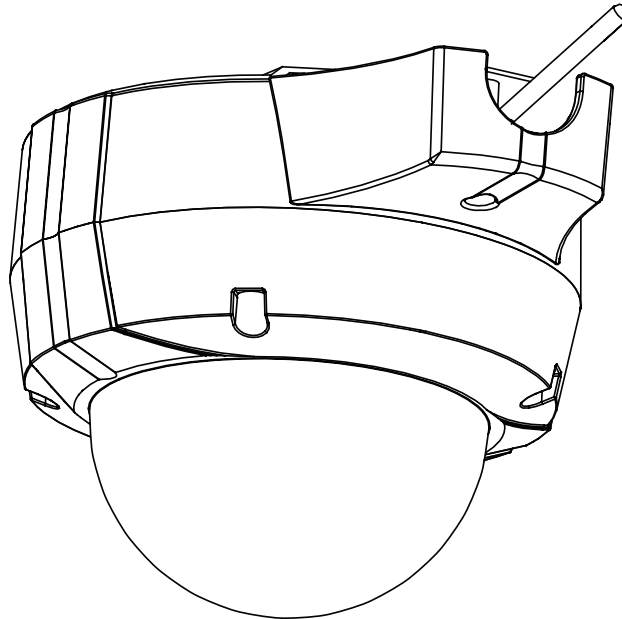

Pendant Mount (Optional)

- Height: 201 mm (7.9 inches)
- Diameter: 150 mm (5.9 inches)
- Weight: 665 g (1.45 lbs)

1. Attach the mounting plate to the bracket cap using the three screws.
2. Locate a suitable position on the ceiling for a 34mm (+2 / -0 mm) hole to be cut. A template is included to aid in marking the mounting hole.
3. Cut a hole in the ceiling according to the template.
4. Drill four separate 6mm holes corresponding to the holes in the mounting template and insert the plastic anchors into these holes.
5. Place the rubber seal between the pendant bracket and the ceiling to ensure a waterproof seal between the ceiling and the bracket.
6. Attach the pendant bracket to the ceiling using the screws provided.
7. Attach the bracket cap to the bottom of the pendant bracket by rotating the cap counterclockwise to tighten it into place.
8. Insert the screw into the base of the pendant bracket at the top of the bracket cap to secure the bracket cap into place.

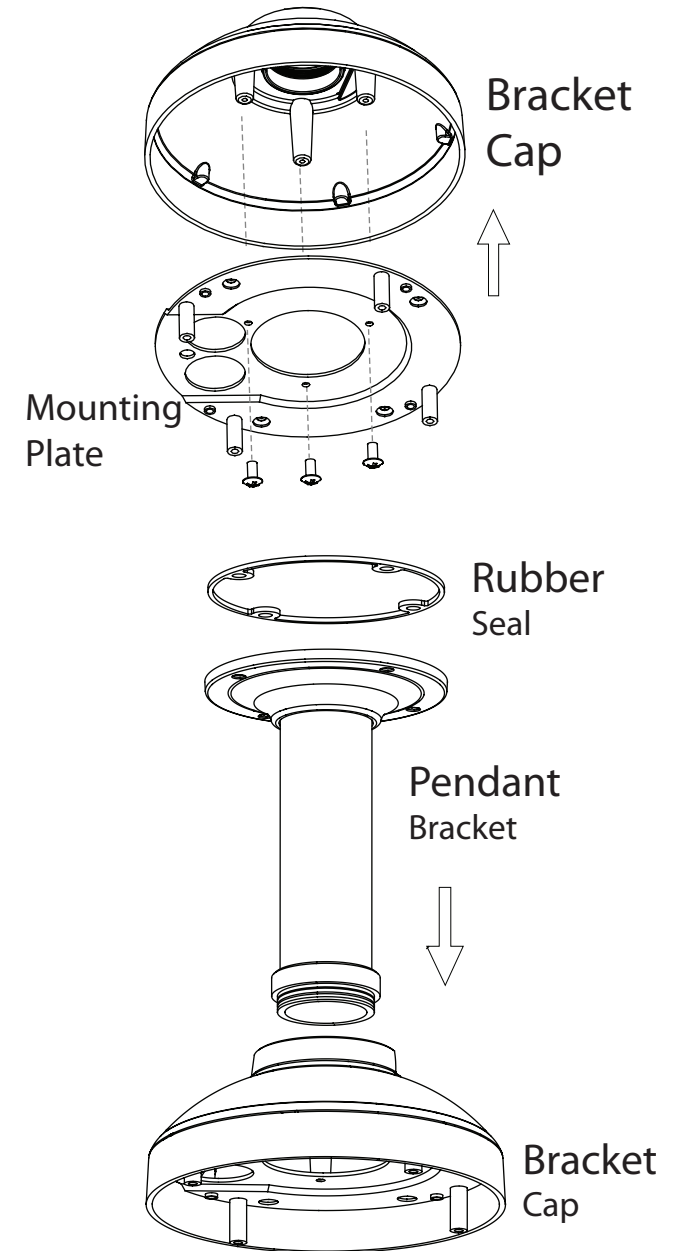

1. Connect the Ethernet cable and the power cable, then thread them through the pendant bracket.
2. Place the dome body onto the base of the camera.

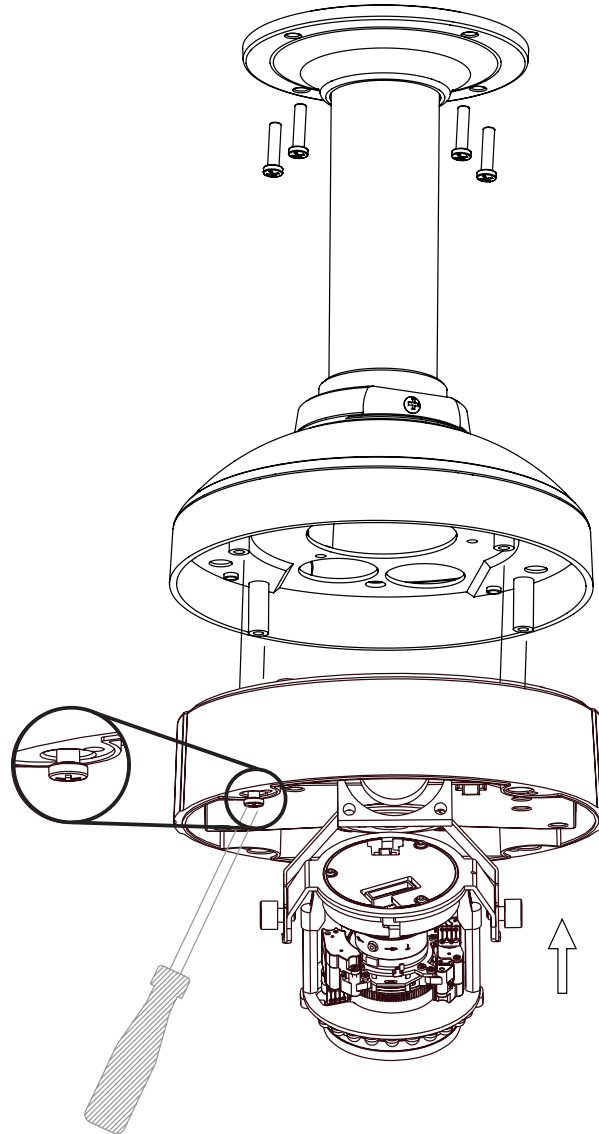

1. Attach the dome to the base of the camera using the three long screws and the provided security screw.

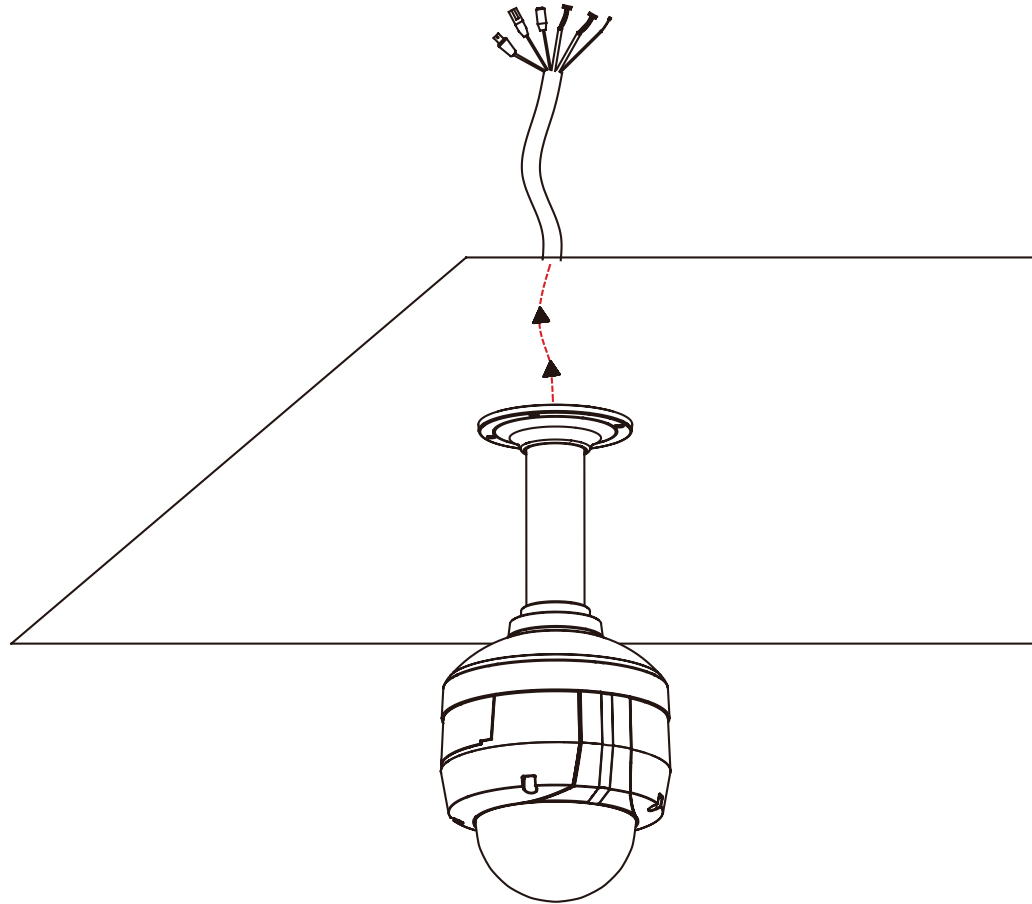

Bent Mount (Optional)

- Height: 253 mm (9.96 inches)
- Diameter: 150 mm (5.9 inches)
- Weight: 770 g (1.7 lbs)

1. Attach the mounting plate to the bracket cap using the three screws.
2. Locate a suitable position on the wall for a 34mm (+2 / -0 mm) hole to be cut. A template is included to aid in marking the mounting hole.
3. Cut a hole in the ceiling according to the template
4. Drill four separate 6mm holes corresponding to the holes in the mounting template and insert the plastic anchors into these holes.
5. Place the rubber seal between the wall mount bracket and the wall to ensure a waterproof seal between the wall and the bracket.
6. Attach the wall mount bracket to the wall using the screws provided.
7. Attach the bracket cap to the bottom of the wall mount bracket by rotating the cap counterclockwise to tighten it into place.
8. Insert the screw into the base of the wall mount bracket at the top of the bracket cap to secure the bracket cap into place.
9. Connect the Ethernet cable and the power cable and thread them through the wall mount bracket.

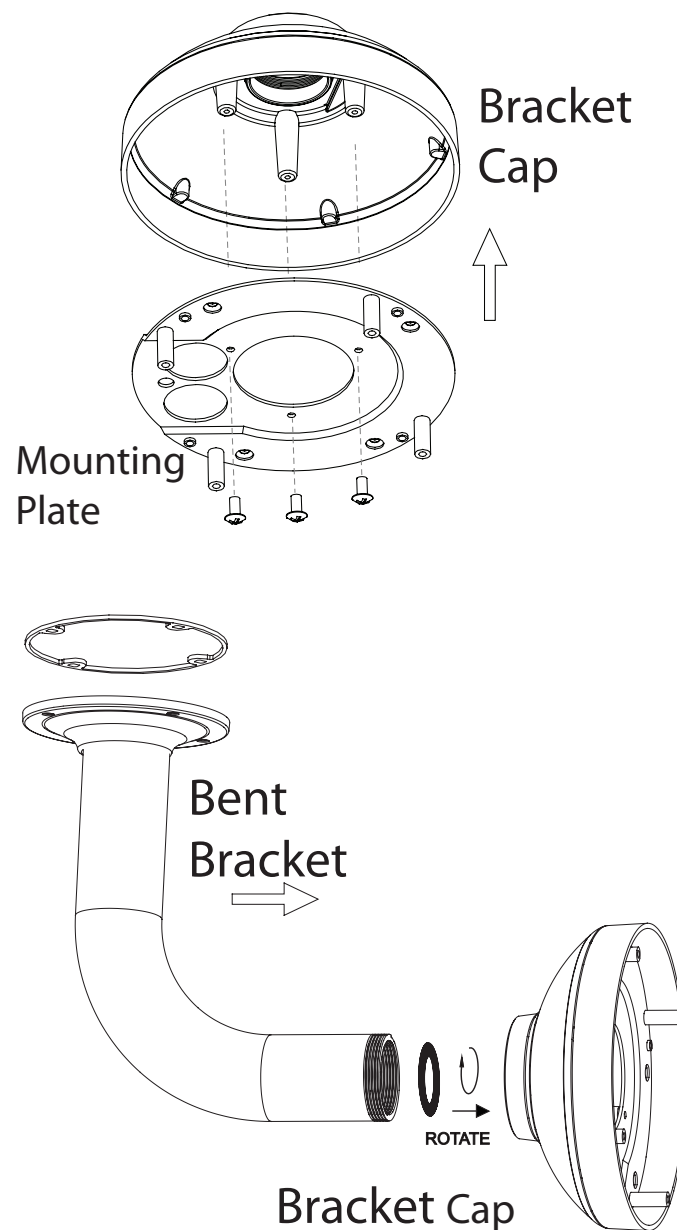

1. Place the dome body onto the base of the camera.

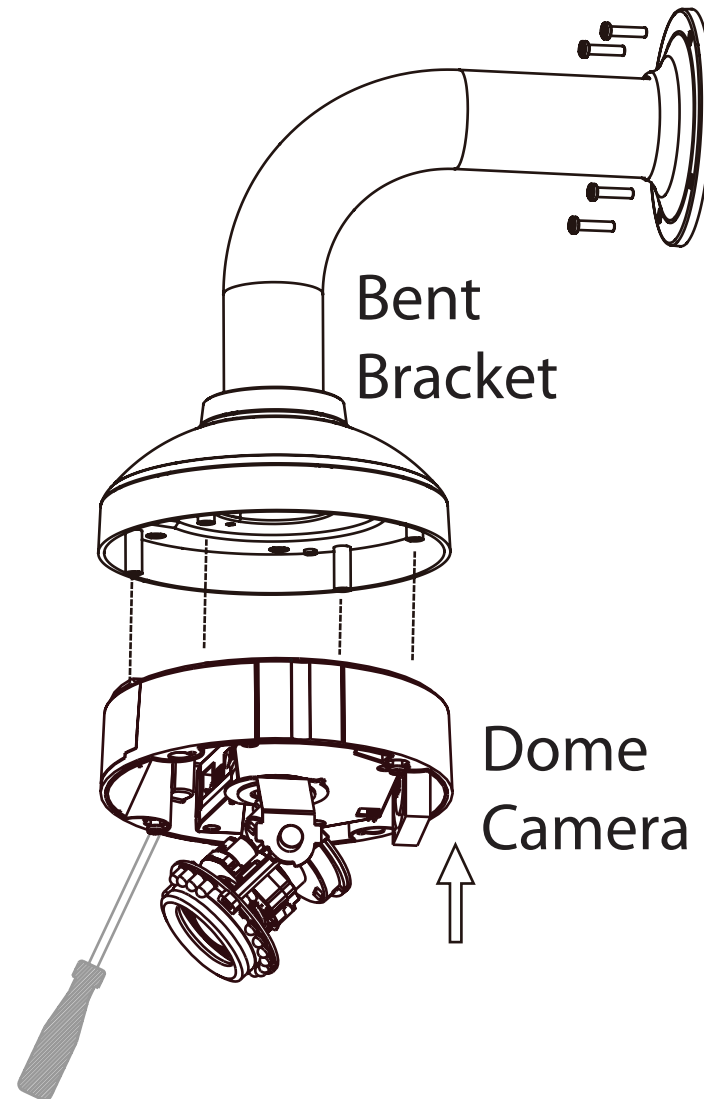

1. Attach the dome to the base of the camera using the three long screws and the provided security screw.

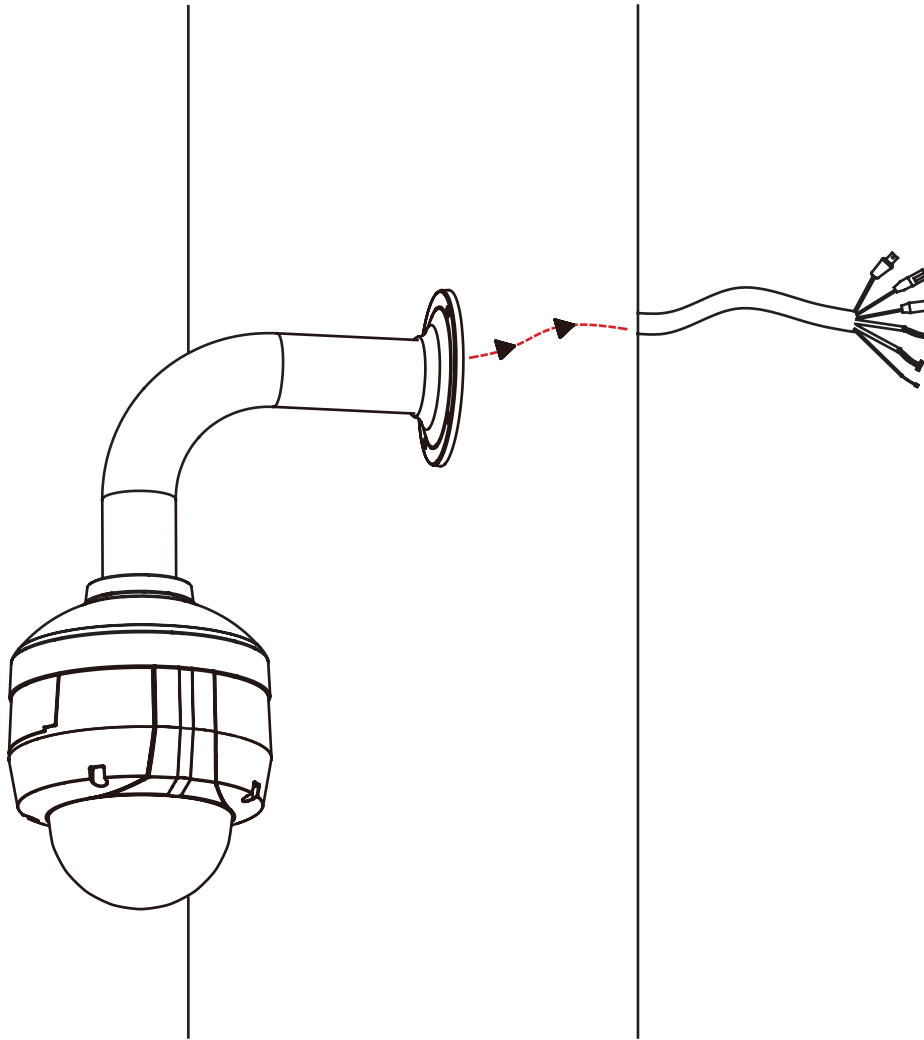

Installation of Weather Shield

The DCS-6513 comes with an optional weather shield to protect your network camera against damage from adverse weather. If you are installing the DCS-6513 in a location where it will be exposed to harsh weather, it is recommended that you install the weather shield.

The weather shield should be installed before you commence mounting or connecting the camera in its final location. To install the weather shield, you will require the 37mm screws which were included in the product package.

Step 1: Using a screwdriver, remove the existing two screws which were pre-installed in the collar of the camera

Step 2: Place the weather shield over the dome of the camera and align the screw holes with the holes in the collar of the camera

Step 3: Install the 37mm screws into the existing screw holes so that they hold the weather shield in place

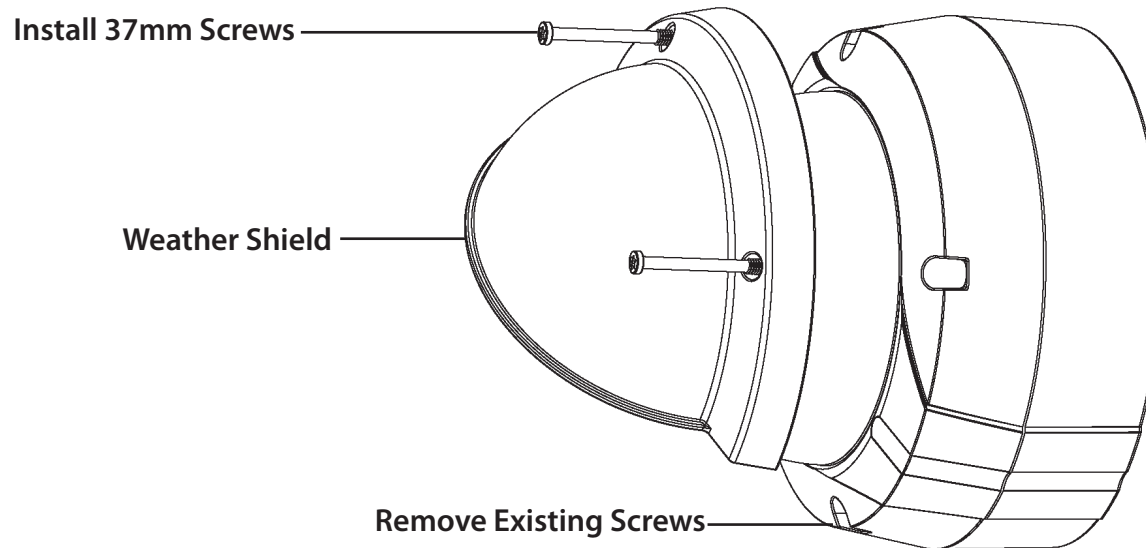

General Connection Using 12 V DC Power Adapter

1. Connect the network camera to a hub via an Ethernet cable.
2. Connect the supplied power cable from the camera to a power outlet.

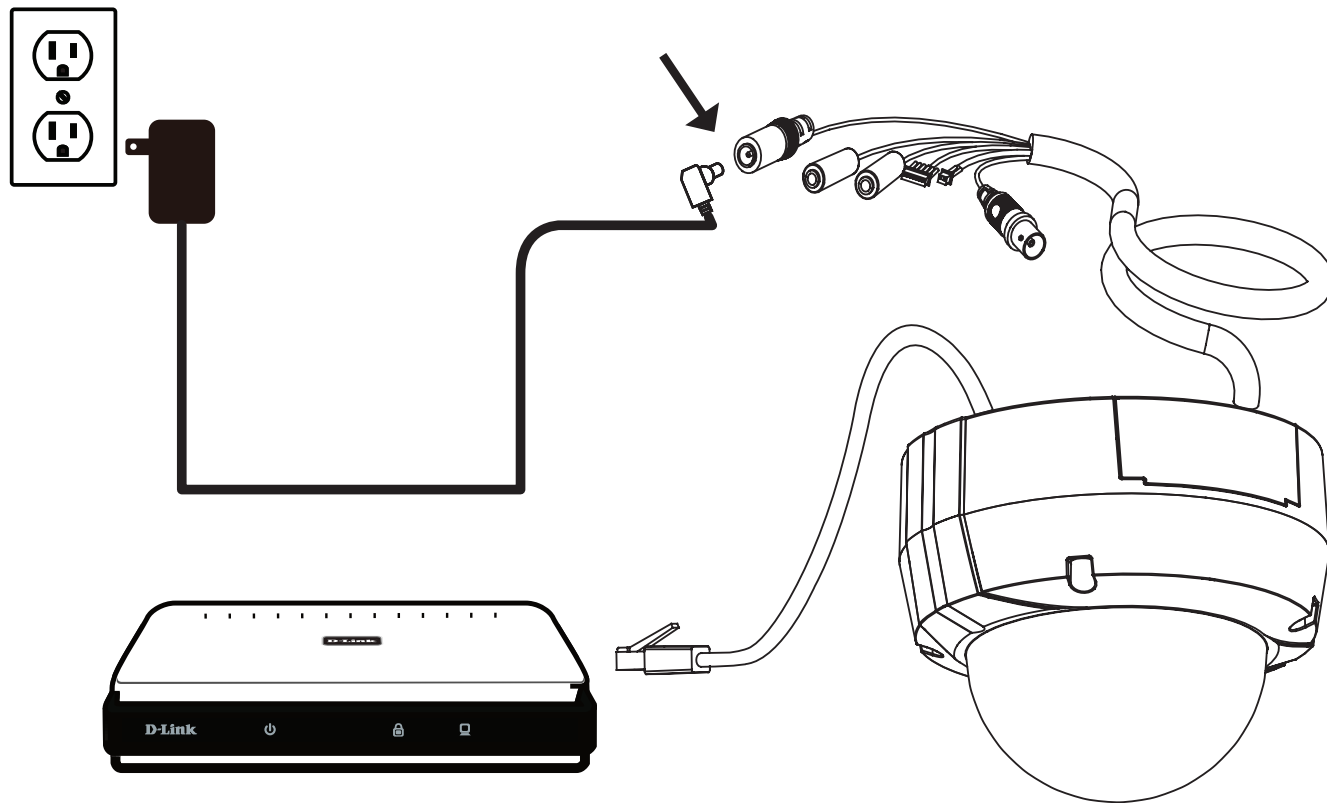

General Connection Using 24 V AC Power Wiring

1. Connect the network camera to a hub via an Ethernet cable.
2. Connect the supplied power cable from the camera to a power source.

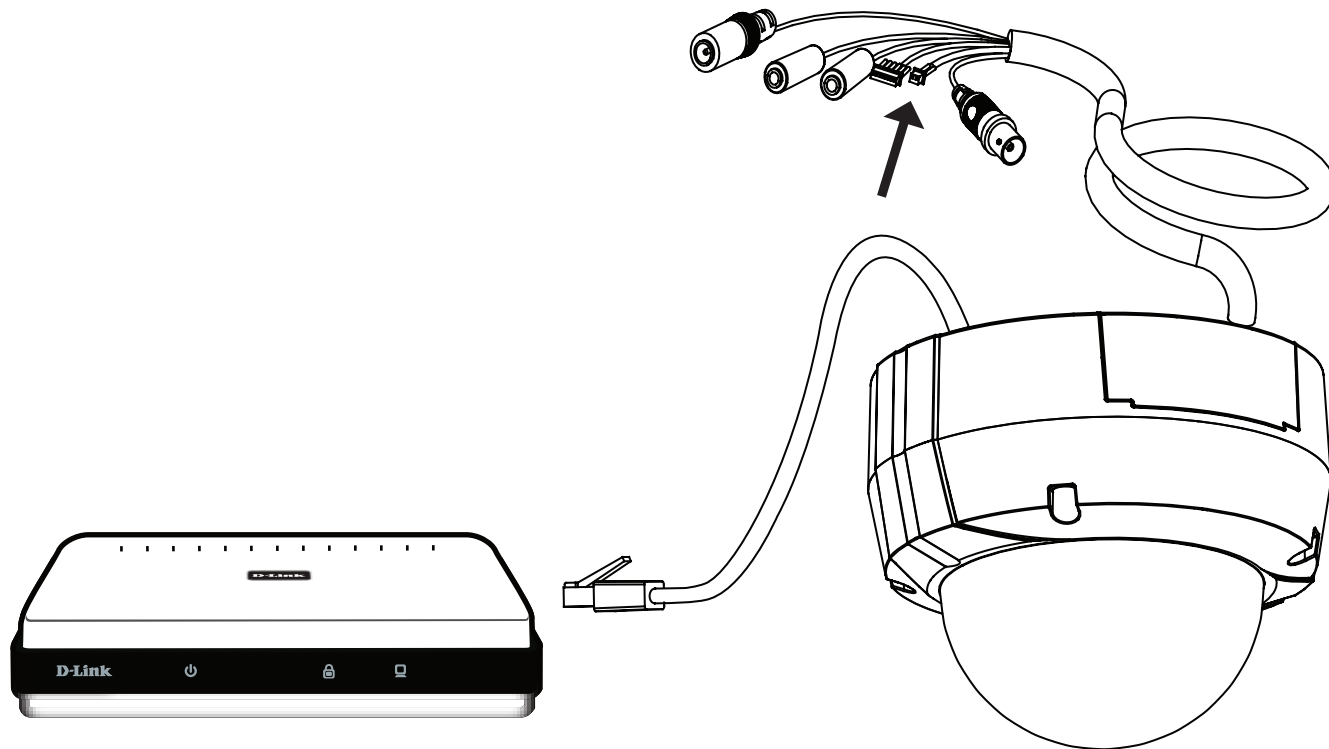

Connection with a PoE Hub

1. If you are using a PoE hub, connect the IP camera to the hub via an Ethernet cable, which will provide transmission of both power and data over a single cable.

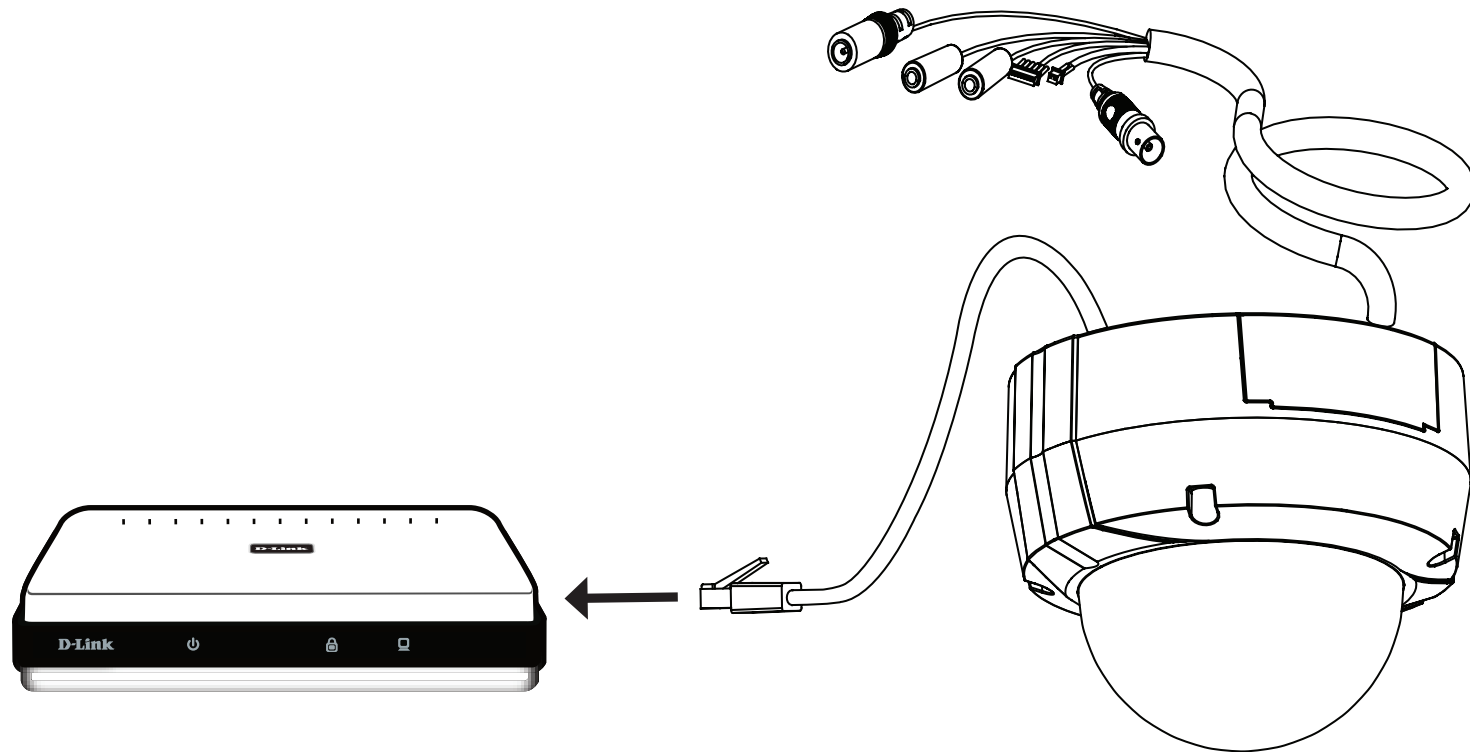

Adjusting the lens 3-axis angle

Adjust the Viewing Angle of the 3-axis Mechanism

Turn the lens module left and right until the desired position is achieved. Tighten the pan screw once completed.

Loosen the tilt screws on both sides of the camera, and turn the lens module up and down until the desired position is achieved; tighten the tilt screws once completed.

Turn the lens to adjust the IP camera's image until the desired orientation is achieved, tighten the image adjustment screw once completed.

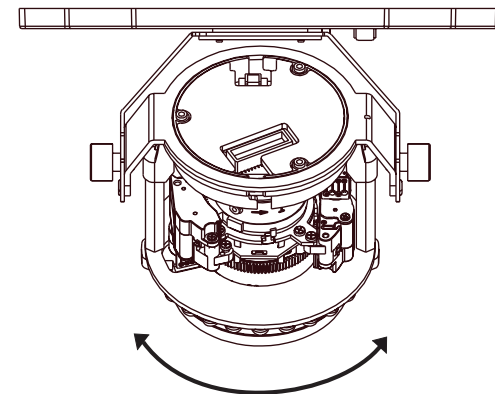
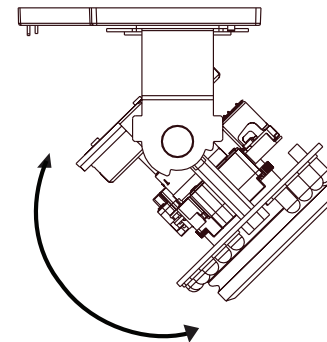
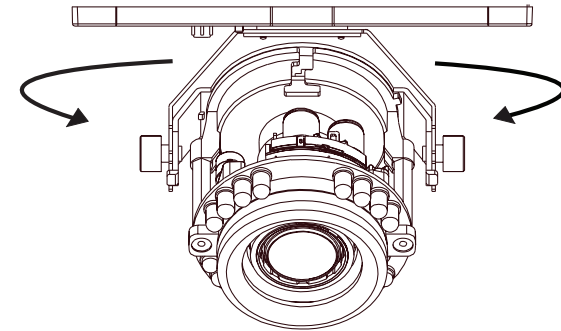

Software Installation

Step 1

Insert the Installation CD-ROM into your computer's optical drive to start the autorun program.

The CD-ROM will open the Camera Installation Wizard. The Setup Wizard will guide you through the installation process through to configuring your camera.

Note:

If the autorun program does not automatically start on your computer, go to Windows, click **Start > Run**. In the Run command box type **D:\DCS6513.exe**, where D: represents your CD-ROM drive.



Step 2

Accept the End User Licence Agreement and follow the on screen prompts to install the Camera Installation Wizard.

Step 3

Select your camera from the list, then click **Wizard**. If you have multiple cameras, you can identify them by the MAC ID printed on the label on the back of your camera.

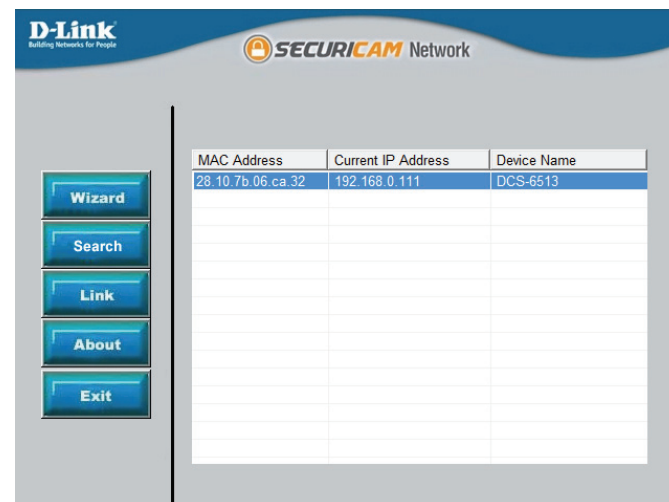

Step 4

By default the **Admin ID** is "admin" and the password field is left blank.

It is recommended that you create and confirm a password for your device. Click **Next** to continue.

The screenshot shows the 'SECURICAM Network' setup interface. At the top, it says 'Set up an Admin ID and Password to secure your camera. Click Next to continue.' Below this, there are two columns of input fields. The first column has 'Admin ID' and 'Password' fields. The second column has 'New ID', 'New Password', and 'Reconfirm' fields. Each of these second-column fields has a 'Change' checkbox to its left. At the bottom right, there are three buttons: 'Back' (left arrow), 'Next' (right arrow), and 'Exit' (red square with white 'X').

Step 5

Select **Static IP** if your Internet Service Provider has provided you with connection settings, or if you wish to set a static address within your home network. Enter the correct configuration information and click **Next** to continue.

Note: Select DHCP if you are unsure of which settings to choose.

Click **Next** to continue.

The screenshot shows the 'Set IP Address' configuration screen. It has two radio buttons: 'DHCP' (which is selected) and 'Static IP'. Below these are five input fields: 'IP Address', 'Subnet Mask', 'Default Gateway', 'Primary DNS', and 'Secondary DNS'. At the bottom right, there are three buttons: 'Back' (left arrow), 'Next' (right arrow), and 'Exit' (red square with white 'X').

Step 6

Confirm your camera login details and IP address details and click **Restart**.

The LED on the front of the DCS-6513 will blink, then turn solid green once it successfully connects to your network..



Step 7

Your DCS-6513 camera is now set up, Click **Exit** to exit the wizard and can skip to "Configuration" on page 31 for advanced configuration of your camera.



D-ViewCam Setup Wizard

D-ViewCam software is included for the administrator to manage multiple D-Link IP cameras remotely. You may use the software to configure all the advanced settings for your cameras. D-ViewCam is a comprehensive management tool for IP surveillance.

Step 1

Insert the CD-ROM into the CD-ROM drive. Click "Install D-ViewCam Software" from menu, and select "D-ViewCam" to install the VMS software.

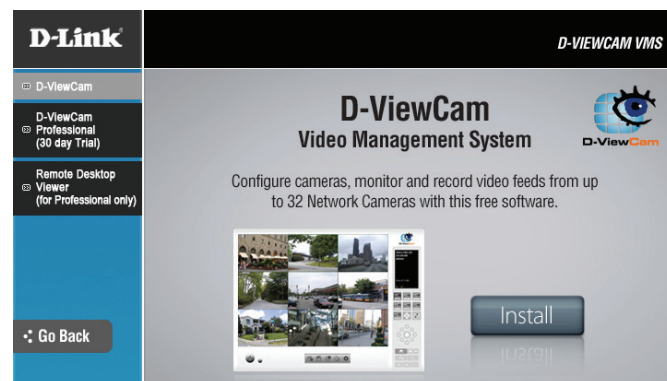

Step 2

Follow the Installation Wizard to install D-ViewCam.

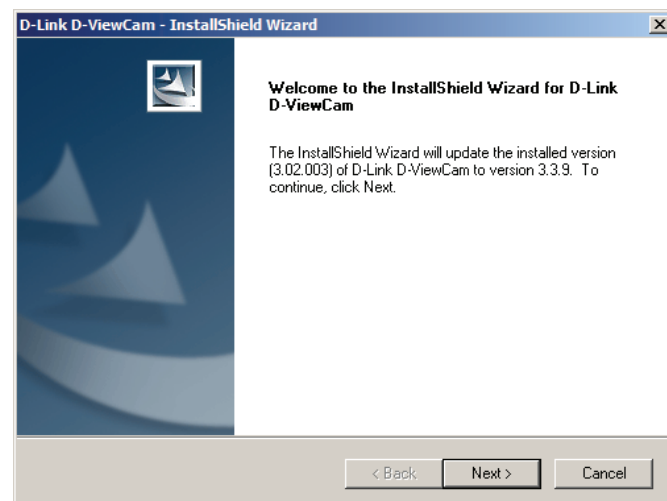

Step 3

Click **Finish** to complete the installation.

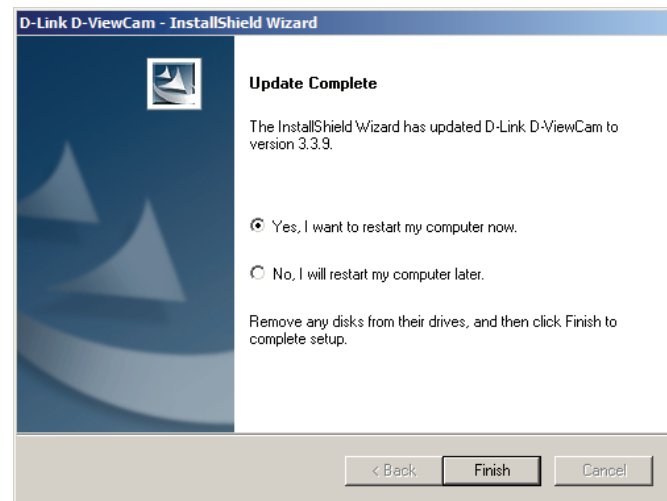

Step 4

To start D-ViewCam, select **Start > All Programs > D-Link D-ViewCam > Main Console**.

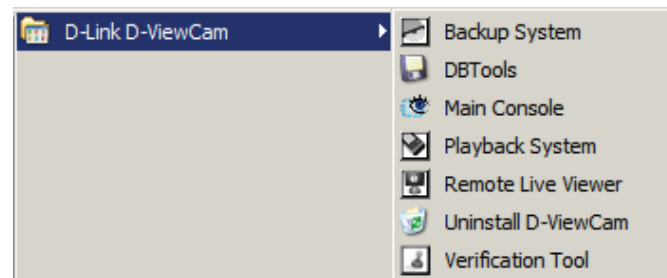

Step 5

For more detailed operation of using D-ViewCam software, please refer to the D-ViewCam Manual.

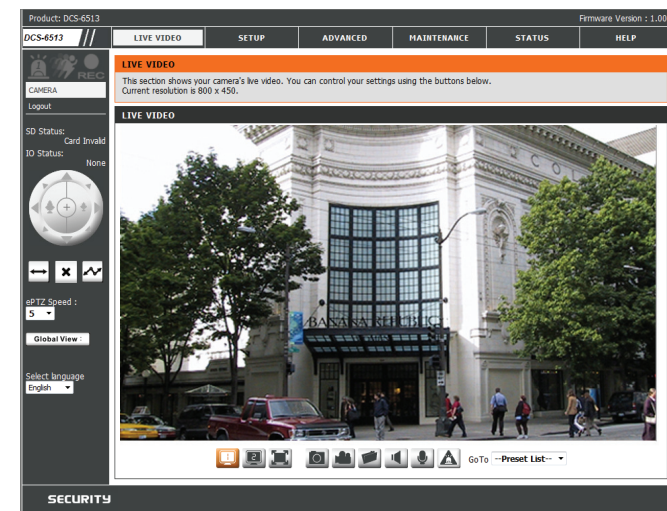

Configuration

Using the Configuration Interface

After completing the Camera Installation Wizard, you are ready to use your camera. The camera's built-in Web configuration utility is designed to allow you to easily access and configure your DCS-6513. At the end of the wizard, click **Link**, or enter the IP address of your camera into a web browser, such as Mozilla Firefox. To log in, use the User name **admin** and the password you created in the Installation Wizard. If you did not create a password, the default password is blank. After entering your password, click **OK**.

Step 1

Click the **Link** button on the Wizard.

The Setup Wizard will automatically open your web browser to the IP address of the camera.



Step 2

Enter your credentials to access the configuration interface.

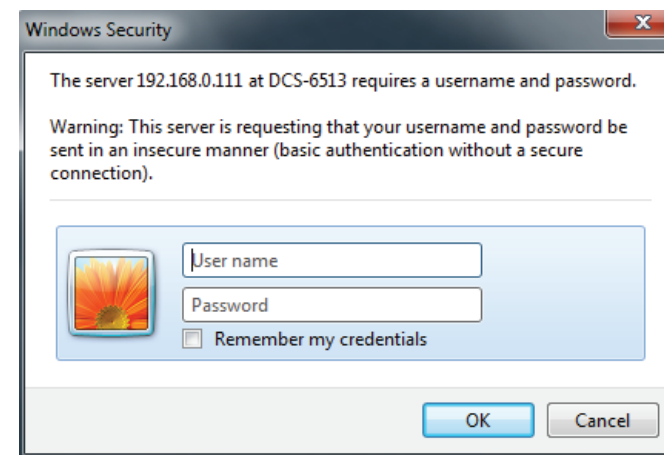







Live Video

This section shows your camera's live video. You may select any of the available icons listed below to operate the camera. You may also select your language using the drop-down menu on the left side of the screen.

You can zoom in and out on the live video image using your mouse. Right-click to zoom out or left-click to zoom in on the image.

SD Status: This option displays the status of the SD card. If no SD card has been inserted, this screen will display the message "Card Invalid."

IO Status: This option displays the status of your I/O device if a device has been connected.



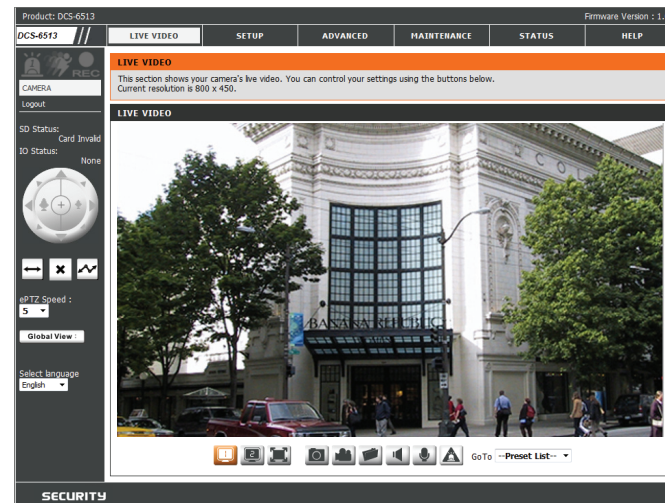







	Digital Input Indicator	This indicator will change color when a digital input signal is detected.
	Motion Trigger Indicator	This indicator will change color when a trigger event occurs. Note: The video motion feature for your camera must be enabled.
	Recording Indicator	When a recording is in progress, this indicator will change color.
	Control Pad	This control pad can be used to electronically pan, tilt, and zoom (ePTZ) within the camera's predefined view area, if one has been defined.
	Auto Pan	Starts the automatic panning function. The ROI will pan from back and forth within the FOV
	Stop	Stops the camera ePTZ motion
	Preset Path	Starts the camera's motion along the predefined path



ePTZ Speed: You may select a value between 0 and 10. 0, where 1 is the slowest and 10 is the fastest.

Global View: This window indicates the total Field of View (FOV) of the camera. The red box indicates the visible Region of Interest (ROI).

Language: You may select the interface language using this menu.

- | | |
|--|--|
|  Video Profile 1 |  Record a Video Clip |
|  Video Profile 2 |  Set a Storage Folder |
|  Video Profile 3 |  Listen/Stop Audio In (from microphone) |
|  Full screen mode |  Start/Stop Audio Out (to speaker) |
|  Take a Snapshot |  Start/Stop Digital Output |

Go To: If any presets have been defined, selecting a preset from this list will (**Preset List**) display it.

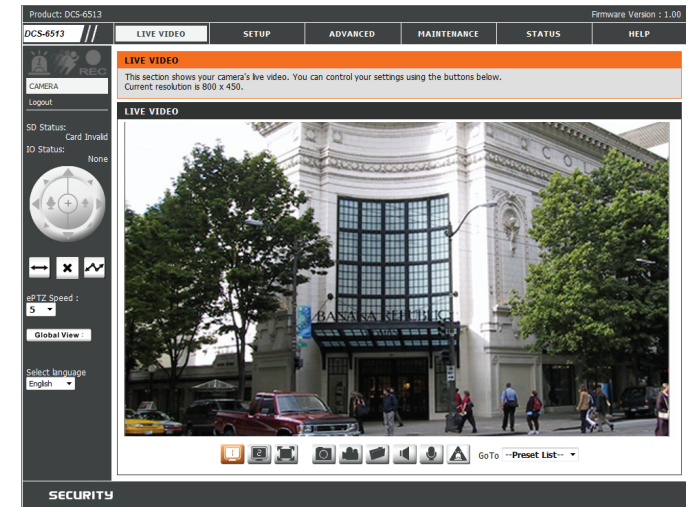

Setup Setup Wizard

To configure your Network Camera, click **Internet Connection Setup Wizard**. Alternatively, you may click **Manual Internet Connection Setup** to manually configure your Network Camera and skip to "Network Setup" on page 40.

To quickly configure your Network Camera's motion detection settings, click **Motion Detection Setup Wizard**. If you want to enter your settings without running the wizard, click **Manual Motion Detection Setup** and skip to "Motion Detection" on page 51.

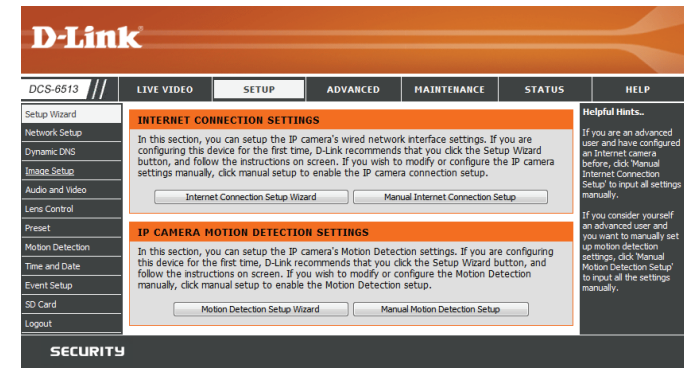

Internet Connection Setup Wizard

This wizard will guide you through a step-by-step process to configure your new D-Link Camera and connect the camera to the internet. Click **Next** to continue.

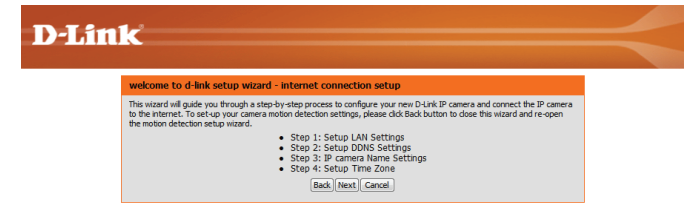

If your internet service provider has not provided you with connection settings, or you are unsure of which settings to choose, select DHCP.

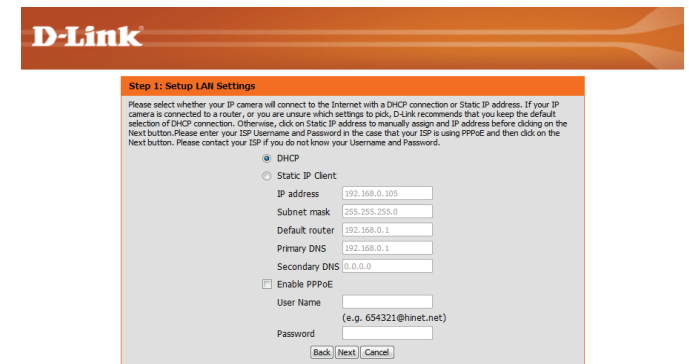

Click **Next** to continue.

Section 3: Configuration

Select **Static IP** if your Internet Service Provider has provided you with connection settings, or if you wish to set a static address within your home network. Enter the correct configuration information and click **Next** to continue.

If you are using PPPoE, select **Enable PPPoE** and enter your user name and password, otherwise click **Next** to continue.

If you have a Dynamic DNS account and would like the camera to update your IP address automatically, Select **Enable DDNS** and enter your host information. Click **Next** to continue.

Enter a name for your camera and click **Next** to continue.

D-Link

Step 1: Setup LAN Settings

Please select whether your IP camera will connect to the Internet with a DHCP connection or Static IP address. If your IP camera is connected to a router, or you are unsure which settings to pick, D-Link recommends that you keep the default selection of DHCP connection. Otherwise, click on Static IP address to manually assign and IP address before clicking on the Next button. Please enter your ISP Username and Password in the case that your ISP is using PPPoE and then click on the Next button. Please contact your ISP if you do not know your Username and Password.

DHCP

Static IP Client

IP address 192.168.0.103

Subnet mask 255.255.255.0

Default router 192.168.0.1

Primary DNS 192.168.0.1

Secondary DNS 0.0.0.0

Enable PPPoE

User Name
(e.g. 654321@hinet.net)

Password

D-Link

Step 2: Setup DDNS Settings

If you have a Dynamic DNS account and would like the IP camera to update your IP address automatically, enable DDNS and enter in your host information below. Please click on the Next button to continue.

Enable DDNS

Server Address <<

Host Name

User Name

Password

Verify Password

Timeout 24 (hours)

D-Link

Step 3: IP camera Name Settings

D-Link recommends that you rename your IP camera for easy accessibility. You can then identify and connect to your IP camera via this name. Please assign a name of your choice before clicking on the Next button.

IP camera Name

Section 3: Configuration

Configure the correct time to ensure that all events will be triggered as scheduled. Click **Next** to continue.

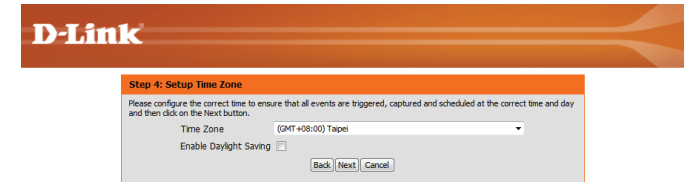

Confirm the settings are correct and click **Apply** to save them.

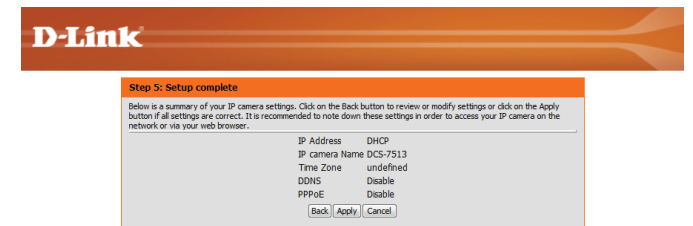

The settings will be saved to the DCS-6513 and the camera will restart.

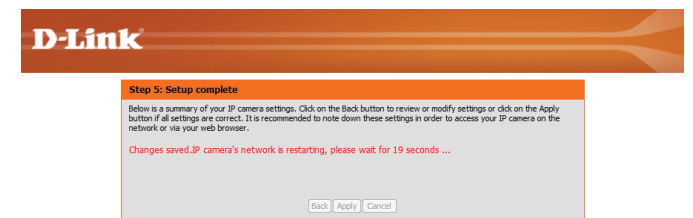

Motion Detection Setup Wizard

This wizard will guide you through a step-by-step process to configure your camera's motion detection functions.

Click **Next** to continue.

Step 1

This step will allow you to enable or disable motion detection, specify the detection sensitivity, and adjust the camera's ability to detect movement.

You may specify whether the camera should capture a snapshot or a video clip when motion is detected.

Please see the **Motion Detection** section on "Motion Detection" on page 51 for information about how to configure motion detection.

Step 2

This step allows you to enable motion detection based on a customized schedule. Specify the day and hours. You may also choose to always record whenever motion is detected.

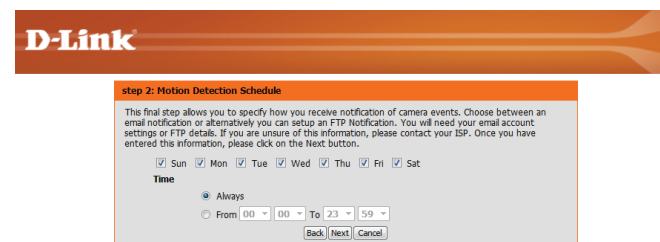
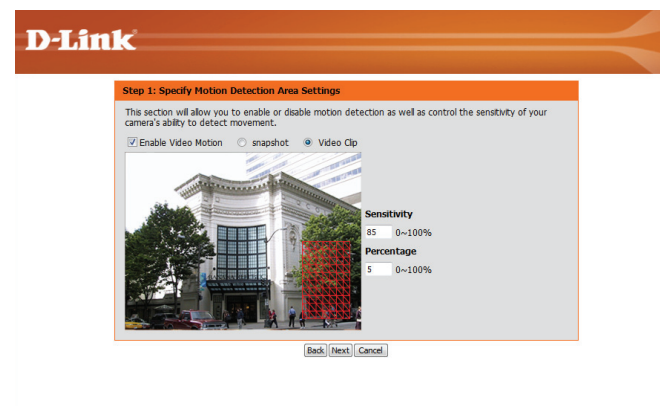
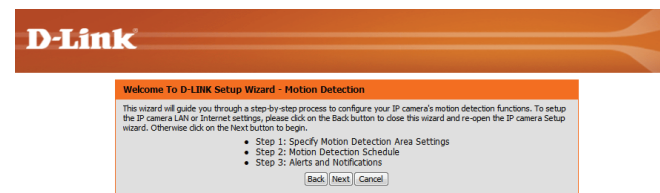

Step 3

This step allows you to specify how you will receive event notifications from your camera. You may choose not to receive notifications, or to receive notifications via e-mail or FTP.

Please enter the relevant information for your e-mail or FTP account.

Click **Next** to continue.

D-Link

Step 3: Alerts and Notification

This final step allows you to specify how you receive notification of camera events. Choose between an email notification or alternatively you can setup an FTP Notification. You will need your email account settings or FTP details. If you are unsure of this information, please contact your ISP. Once you have entered this information, please click on the Next button.

The Sender email address should be filled.

Do not notify me

Email

Sender email address: d@link.com

Recipient email address: d@link.com

Server address: mail.dlink.com

User name: dee

Password: ****

Port: 25

FTP

Server address: []

Port: 21

User name: []

Password: []

Remote folder name: []

Back Next Cancel

Step 4

You have completed the Motion Detection Wizard.

Please verify your settings and click **Apply** to save them.

D-Link

Step 4: Setup Complete

You have completed your IP camera setup. Please click the Back button if you want to review or modify your settings or click on the Apply button to save and apply your settings.

Motion Detection : Enable

EVENT : Video Clip

Schedule Day : Sun , Mon , Tue , Wed , Thu , Fri , Sat ,

Schedule Time : Always

Alerts and Notification : Email

Back Apply Cancel

Please wait a few moments while the camera saves your settings and restarts.

D-Link

Step 4: Setup Complete

You have completed your IP camera setup. Please click the Back button if you want to review or modify your settings or click on the Apply button to save and apply your settings.

Changes saved.IP camera's network is restarting, please wait for 6 seconds ...

Back Apply Cancel

Network Setup

Use this section to configure the network connections for your camera. All relevant information must be entered accurately. After making any changes, click the **Save Settings** button to save your changes.

LAN Settings: This section lets you configure settings for your local area network.

DHCP: Select this connection if you have a DHCP server running on your network and would like your camera to obtain an IP address automatically.

If you choose DHCP, you do not need to fill out the IP address settings.

Static IP Client: You may obtain a static or fixed IP address and other network information from your network administrator for your camera. A static IP address may simplify access to your camera in the future.

IP Address: Enter the fixed IP address in this field.

Subnet Mask: This number is used to determine if the destination is in the same subnet. The default value is 255.255.255.0.

Default Gateway: The gateway used to forward frames to destinations in a different subnet. Invalid gateway settings may cause the failure of transmissions to a different subnet.

Primary DNS: The primary domain name server translates names to IP addresses.

Secondary DNS: The secondary DNS acts as a backup to the primary DNS.

The screenshot displays the 'NETWORK SETUP' page for a D-Link DCS-6513 camera. The page is organized into several sections:

- LAN SETTINGS:** The 'DHCP' radio button is selected. Below it, the 'Static IP Client' section is visible with input fields for IP address (192.168.0.111), Subnet mask (255.255.255.0), Default router (192.168.0.1), Primary DNS (192.168.0.1), and Secondary DNS (0.0.0.0). There are also checkboxes for 'Enable UPnP presentation' and 'Enable UPnP port forwarding'.
- PPPoE SETTINGS:** The 'Disable' radio button is selected. Fields for User Name, Password, and Confirm password are present. The status shows 'PPPoE is inactive'.
- HTTP:** The HTTP port is set to 80. Access names for stream1 and stream2 are 'video1.mjpg' and 'video2.mjpg' respectively.
- HTTPS:** The HTTPS port is set to 443.
- RTSP:** Authentication is set to 'Disable'. The RTSP port is 554. Access names for stream1 and stream2 are 'live1.sdp' and 'live2.sdp'.
- CoS SETTINGS:** The 'Enable CoS' checkbox is checked. The VLAN ID is set to 1. Live video and Live audio are both set to 0.

Enable UPnP Presentation: Enabling this setting allows your camera to be configured as a UPnP device on your network.

Enable UPnP Port Forwarding: Enabling this setting allows the camera to add port forwarding entries into the router automatically on a UPnP capable network.

Enable PPPoE: Enable this setting if your network uses PPPoE.

User Name / Password: Enter the username and password for your PPPoE account. Re-enter your password in the Confirm Password field. You may obtain this information from your ISP.

HTTP Port: The default port number is 80.

Access Name for Stream 1~3: The default name is video#.mjpg, where # is the number of the stream.

HTTPS Port: You may use a PC with a secure browser to connect to the HTTPS port of the camera. The default port number is 443.

Authentication: Choose to enable or disable RTSP digest encryption. Digest encryption uses MD5 hashes.

RTSP Port: The port number that you use for RTSP streaming to mobile devices, such as mobile phones or PDAs. The default port number is 554. You may specify the address of a particular stream. For instance, live1.sdp can be accessed at rtsp://x.x.x.x/video1.sdp where the x.x.x.x represents the ip address of your camera.



Enable CoS: Enabling the Class of Service setting implements a best-effort policy without making any bandwidth reservations.

Enable QoS: Enabling QoS allows you to specify a traffic priority policy to ensure a consistent Quality of Service during busy periods. If the Network Camera is connected to a router that itself implements QoS, the router's settings will override the QoS settings of the camera.

Enable IPv6: Enable the IPv6 setting to use the IPv6 protocol. Enabling the option allows you to manually set up the address, specify an optional IP address, specify an optional router and an optional primary DNS.

Enable Multicast for stream The DCS-6513 allows you to multicast each of the available streams via group address and specify the TTL value for each stream. Enter the port and TTL settings you wish to use if you do not want to use the defaults.

The screenshot displays the configuration page for the D-Link DCS-6513, divided into several sections:

- COS SETTINGS:** Includes a checkbox for 'Enable CoS' and dropdown menus for 'VLAN ID' (set to 1), 'Live video' (0), 'Live audio' (0), 'Event/Alarm' (0), and 'Management' (0).
- QoS SETTINGS:** Includes a checkbox for 'Enable QoS' and dropdown menus for 'Live video' (0), 'Live audio' (0), 'Event/Alarm' (0), and 'Management' (0).
- IPv6:** Includes a checkbox for 'Enable IPv6', a 'IPv6 Information' button, and a 'Manually setup the IP address' checkbox. Below are input fields for 'Optional IP address / Prefix length' (with a /64 suffix), 'Optional default router', and 'Optional primary DNS'.
- MULTICAST:** Contains two sections for 'Enable multicast for stream 1' and 'stream 2'. Each section has input fields for 'Multicast group address', 'Multicast video port', 'Multicast RTP video port', 'Multicast audio port', 'Multicast RTP audio port', and 'Multicast TTL [1~255]'. Stream 1 values are 239.1.1.1, 6550, 6551, 6552, 6553, and 64. Stream 2 values are 239.1.1.2, 6554, 6555, 6556, 6557, and 64.

At the bottom, there are 'Save Settings' and 'Don't Save Settings' buttons.

Annotations on the right side of the screenshot:

- Enable IPv6:** Select option and click Save enable IPv6 settings. Please note that this works if your network environment and hardware equipment support IPv6. The browser should be Microsoft Internet Explorer 6.5, Mozilla Firefox 3.0 or above. When IPv6 is enable default, the Network Camera will listen to router advertisements and be assigned a link local IPv6 address accordingly.
- IPv6 Information:** Click this button to obtain IPv6 information. If IPv6 settings are successful, the IPv6 address list will be list in the pop-up window. Please follow the steps below to link to an IP address: 1) Open your web browser. 2) Enter the link-local IPv6 address in the address bar of your web browser. 3) Press Enter on the keyboard or click Refresh button to refresh the webpage.
- Manually setup the address:** Select this option to manually configure IPv6 settings your network environment does not have DHCPv6 server advertisements enabled routers.
- Multicast:** Click the items to display the detailed configuration information. Select Always multicast option to enable multicast for stream 1 ~ 3. Unicast video transmission delivers stream through point-to-point transmission; multicast, on the other hand, sends a stream to the multicast group address and allows multiple clients to access the stream at the same time by requesting it from the multicast address. Therefore, enabling multicast can effectively save network bandwidth.
- Multicast RTP video:**

Dynamic DNS

DDNS (Dynamic Domain Name Server) will hold a DNS host name and synchronize the public IP address of the modem when it has been modified. A user name and password are required when using the DDNS service. After making any changes, click the **Save Settings** button to save your changes.

Enable DDNS: Select this checkbox to enable the DDNS function.

Server Address: Select your Dynamic DNS provider from the pull down menu or enter the server address manually.

Host Name: Enter the host name of the DDNS server.

User Name: Enter the user name or e-mail used to connect to your DDNS account.

Password: Enter the password used to connect to your DDNS server account.

Timeout: Enter the DNS timeout values you wish to use.

Status: Indicates the connection status, which is automatically determined by the system.

The screenshot shows the D-Link web interface for the DCS-6513 device. The main content area is titled "DYNAMIC DNS" and contains the following information:

- Enable DDNS:** A checkbox that is currently unchecked.
- Server Address:** A dropdown menu showing "www.dlinkddns.com" with a double-left arrow icon.
- Host Name:** An empty text input field.
- User Name:** An empty text input field.
- Password:** An empty text input field.
- Verify Password:** An empty text input field.
- Timeout:** A text input field containing "24" followed by "(hours)".
- Status:** A text input field containing "Inactive".

At the bottom of the settings section, there are two buttons: "Save Settings" and "Don't Save Settings".

Image Setup

In this section, you may configure the video image settings for your camera. A preview of the image will be shown in Live Video.

Enable Privacy Mask: The Privacy Mask setting allows you to specify up to 3 rectangular areas on the camera's image to be blocked/excluded from recordings and snapshots.

You may click and drag the mouse cursor over the camera image to draw a mask area. Right clicking on the camera image brings up the following menu options:

Disable All: Disables all mask areas

Enable All: Enables all mask areas

Reset All: Clears all mask areas.

Mirror: This will mirror the image horizontally.

Flip: This will flip the image vertically. When turning Flip on, you may wish to consider turning Mirror on as well.

Power Line: Select the frequency used by your power lines to avoid interference or distortion.

White Balance: Use the drop-down box to change white balance settings to help balance colors for different environments. You can choose from Auto, Outdoor, Indoor, Fluorescent, and Push Hold.

Exposure Mode: Changes the exposure mode. Use the drop-down box to set the camera for Indoor, Outdoor, or Night environments, or to Moving to capture moving objects.

D-Link

DCS-6513 // LIVE VIDEO SETUP ADVANCED MAINTENANCE STATUS HELP

Setup Wizard
Network Setup
Dynamic DNS
Image Setup
Audio and Video
Lens Control
Preset
Motion Detection
Time and Date
Event Setup
SD Card
Logout

IMAGE SETUP
Changes to your IP camera settings are made immediately.

LIVE VIDEO
 Enable Privacy Mask Setting

IMAGE SETTINGS

Mirror On Off
Flip On Off
Power Line 60 Hz 50 Hz
White Balance
Exposure Mode Max Gain db
 Enable automatic Iris adjustment
Denoise
Brightness
Contrast
Saturation
Sharpness
WDR Level

Helpful Hints...
Privacy Mask: Click the attached box to activate this function. Now use your mouse to draw a rectangle covering the area you want hidden. Click the box again to deactivate the function.
Mirror: This function horizontally reverses your images 180 degrees.
Flip: This function vertically reverses your images 180 degrees.
Power Line: This setting is used to remove 50/60 Hz flicker.
White Balance: White Balance is the process of removing unrealistic color casts, so that objects which appear white in person are rendered white in your photo.
Exposure Mode: Exposure is the total amount of light allowed to fall on the image sensor during the process of capturing an image. You may choose different scene modes to produce the better images.
Max Gain: It can always be enabled automatically, but you have an option you can change Max Gain either automatically or manually.
Iris Adjustment: To achieve special inventive effects or to deal with special lighting situations. The iris also can be adjusted manually.
Iris Speed: To adjust opening and closing speed of the iris from "High" to "Low" steps.
Denoise: It is the process of removing noise from a signal.
Brightness: It is used to compensate for backlight scenes.
Contrast: It may help to improve the image under a dull grey sky.
Saturation: It controls the strength of color from black and white to bold colors.
Sharpness: Controls the amount of sharpening applied to the image.
WDR Level: This function enables the camera to be widely applied in high contrast environments such as lobby entrances, parking lots, ATMs, loading areas, and much more.

SECURITY

The Low Noise option will focus on creating a high-quality picture without noise. You can also create 3 different custom exposure modes. The Max Gain setting will allow you to control the maximum amount of gain to apply to brighten the picture.

Enable Automatic Iris Adjustment Selecting this option will allow the camera to automatically determine the optimal iris adjustment.

Iris Adjustment To counteract difficult lighting scenarios you can manually adjust the camera's iris.

Iris Speed This allows you to select the speed at which iris adjustments take place.

Denoise: This setting controls the amount of noise reduction that will be applied to the picture.

Brightness: Adjust this setting to compensate for backlit subjects.

Contrast: Adjust this setting to alter the color intensity/strength.

Saturation: This setting controls the amount of coloration, from grayscale to fully saturated.

Sharpness: Specify a value from 0 to 128 to specify how much sharpening to apply to the image.

WDR Level: Specify a value from 0 to 10 to specify how much WDR to apply to the image, or select **None**.

Reset Default: Click this button to reset the image to factory default settings.

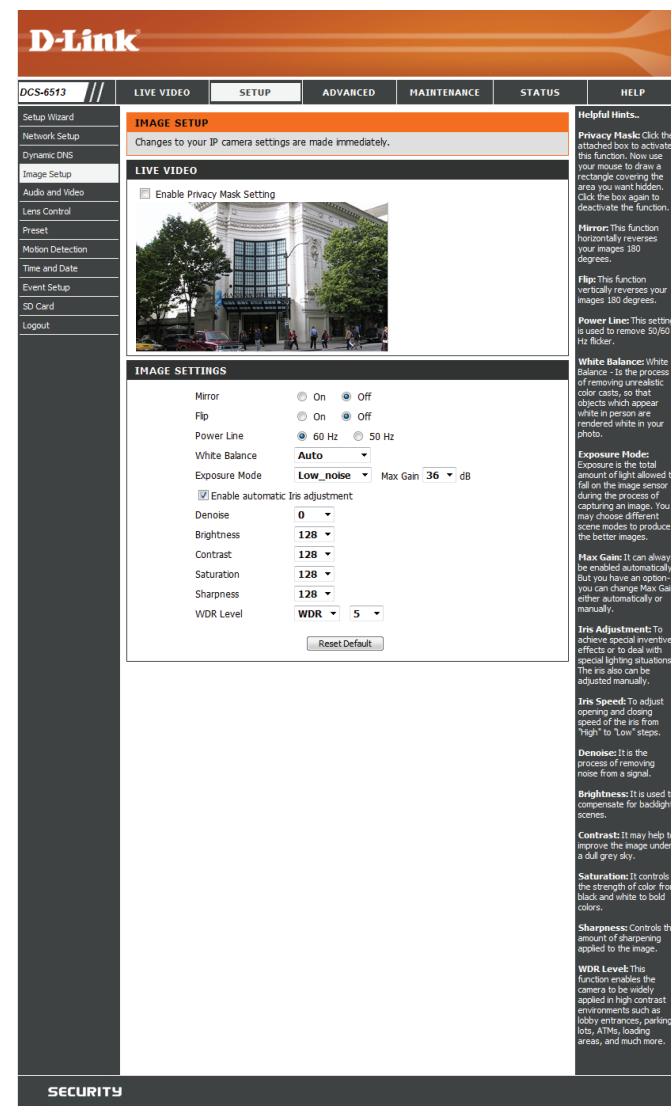

Audio and Video

You may configure up to 3 video profiles with different settings for your camera. Hence, you may set up different profiles for your computer and mobile display. In addition, you may also configure the two-way audio settings for your camera. After making any changes, click the **Save Settings** button to save your changes.

Aspect ratio: Set the aspect ratio of the video to 4:3 standard or 16:9 widescreen.

Mode: Set the video codec to be used to JPEG, MPEG-4, or H.264.

Frame size / View window area: Frame size determines the total capture resolution, and View window area determines the Live Video viewing window size. If the Frame size is larger than the Live Video size, you can use the ePTZ controls to look around.

16:9 1920 x 1080, 1280 x 720, 800 x 450,
640 x 360, 480 x 270, 320 x 176, 176 x 144
up to 30 fps

4:3 1600 x 1200, 1024 x 768, 800 x 600,
640 x 480, 320 x 240, 176 x 144 up to 30 fps
2048 x 1536 at 15 fps

Note: If your View window area is the same as your Frame size, you will not be able to use the ePTZ function.

Maximum frame rate: A higher frame rate provides smoother motion for videos, but requires more bandwidth. Lower frame rates will result in stuttering motion, however will require less bandwidth.

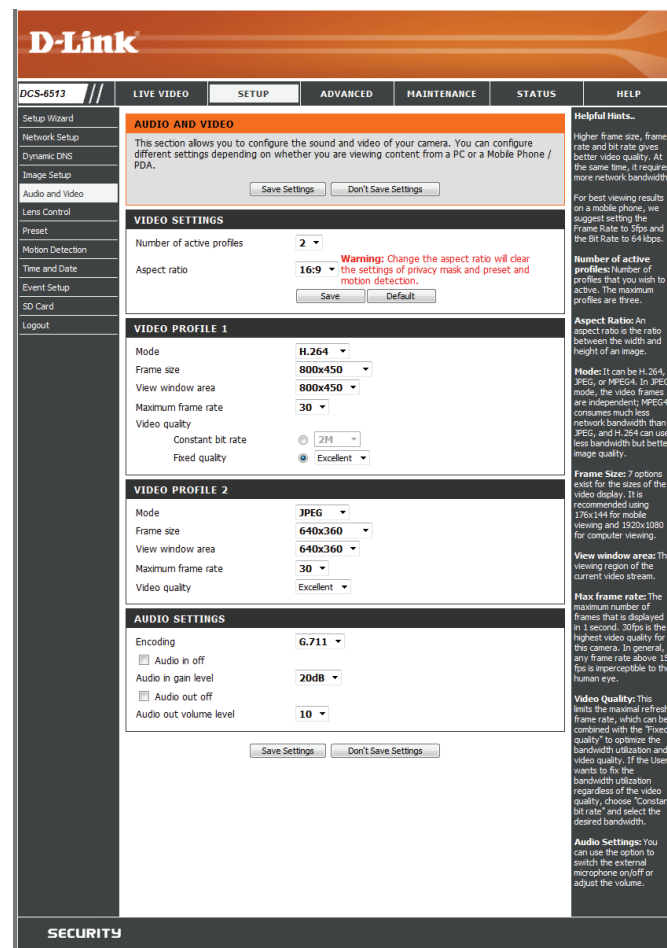

Video Quality: This limits the maximum frame rate, which can be combined with the "Fixed quality" option to optimize the bandwidth utilization and video quality. If fixed bandwidth utilization is desired regardless of the video quality, choose "Constant bit rate" and select the desired bandwidth.

Constant bit rate: The bps will affect the bit rate of the video recorded by the camera. Higher bit rates result in higher video quality.

Fixed quality: Select the image quality level for the camera to try to maintain. High quality levels will result in increased bit rates.

Audio in off: Selecting this checkbox will mute incoming audio.

Audio in gain level: This setting controls the amount of gain applied to incoming audio to increase its volume.

Audio out off: Selecting this checkbox will mute outgoing audio.

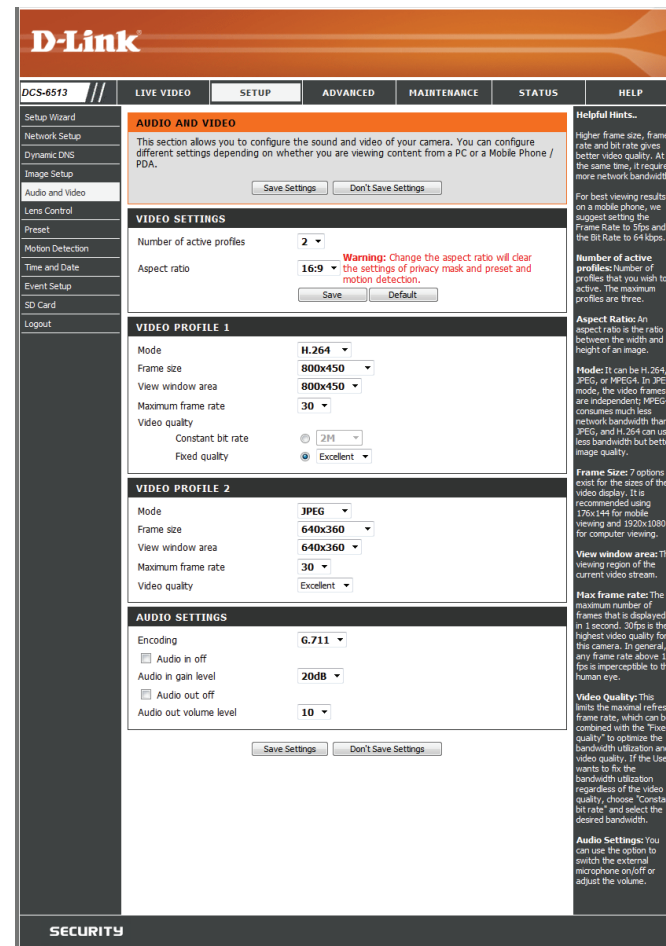

Audio out volume level: This setting controls the amount of gain applied to outgoing audio to increase its volume.



Lens Control

The settings on this page allow you to remotely fine tune the zoom and focus to achieve optimal performance.

Focus Mode: Select an option from the drop down menu.
Auto Allow the camera to automatically adjust
Manual Show the Focus Slider control to allow manual adjustment.

	Zoom Control	Use the slider control to fine tune the camera zoom.
	Focus Control	Use the slider control to fine tune the camera focus.

Fine Tune Focus automatically: Allow the camera to adjust the focus automatically.

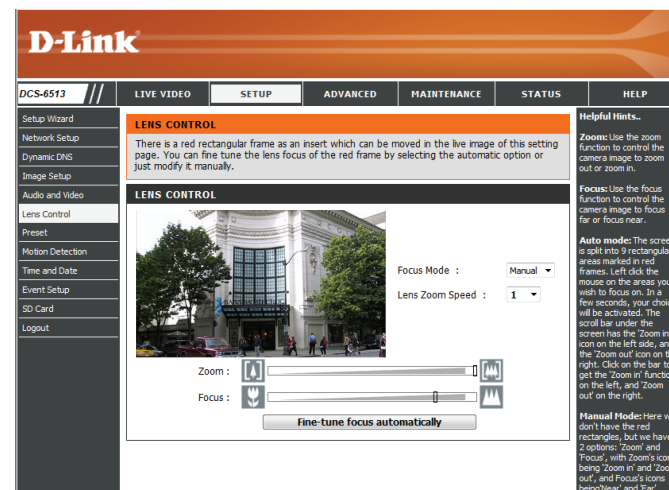

Preset

This screen allows you to set preset points for the ePTZ function of the camera, which allows you to look around the camera's viewable area by using a zoomed view. Presets allow you to quickly go to and view a specific part of the area your camera is covering, and you can create preset sequences, which will automatically change the camera's view between the different presets according to a defined order and timing you can set.

Note: If your View window area is the same as your Frame size, you will not be able to use the ePTZ function.

Video Profile: This selects which video profile to use.

ePTZ Speed: You may select a value between 0 and 10. 0 is the slowest and 10 is the fastest.

Arrow Buttons and Home Button: Use these buttons to move to a specific part of the viewing area, which you can then set as a preset. Click the Home button to return to the center of the viewing area.

Input Preset Name: Enter the name of the preset you want to create, then click the **Add** button to make a new preset. If an existing preset has been selected from the Preset List, you can change its name by typing in a new name, then clicking the **Rename** button.

Preset List: Click this drop-down box to see a list of all the presets that have been created. You can select one, then click the **GoTo** button to change the displayed camera view to the preset. Clicking the **Remove** button will delete the currently selected preset.

Preset Sequence: This section allows you to create a preset sequence, which automatically moves the camera's view between a set of preset views.

The screenshot shows the D-Link DCS-6513 camera web interface. The top navigation bar includes 'LIVE VIDEO', 'SETUP', 'ADVANCED', 'MAINTENANCE', 'STATUS', and 'HELP'. The 'SETUP' menu is expanded to show 'Preset Control'. The main content area is titled 'PRESET CONTROL' and contains a camera view of a building. To the right of the camera view are controls for 'VIDEO PROFILE' (set to 1) and 'ePTZ Speed' (set to 5). Below these are directional arrow buttons (up, down, left, right) and a home button. The 'PRESET' section includes an 'Input Preset Name' field with 'Add' and 'Rename' buttons, and a 'Preset List' dropdown with 'GoTo' and 'Remove' buttons. The 'PRESET SEQUENCE' section includes a 'Preset Name' field, a 'Dwell time' field, and 'Add', 'Update', and 'Remove' buttons. A sidebar on the right contains 'Helpful Hints...' with instructions on how to use the camera controls and create preset sequences.

Preset List: To add a preset to the sequence, select it from the drop-down box at the bottom of this window, set the **Dwell time** to determine how long the camera view will stay at that preset, then click the **Add** button. The preset name will appear in the list, followed by the dwell time to view that preset for.

You can rearrange your presets in the sequence by selecting a preset in the sequence, then clicking the arrow buttons to move it higher or lower in the current sequence.

Clicking the trash can button will remove the currently selected preset from the sequence.

If you want to change the dwell time for a preset, select it from the list, enter a new dwell time, then click the **Update** button.

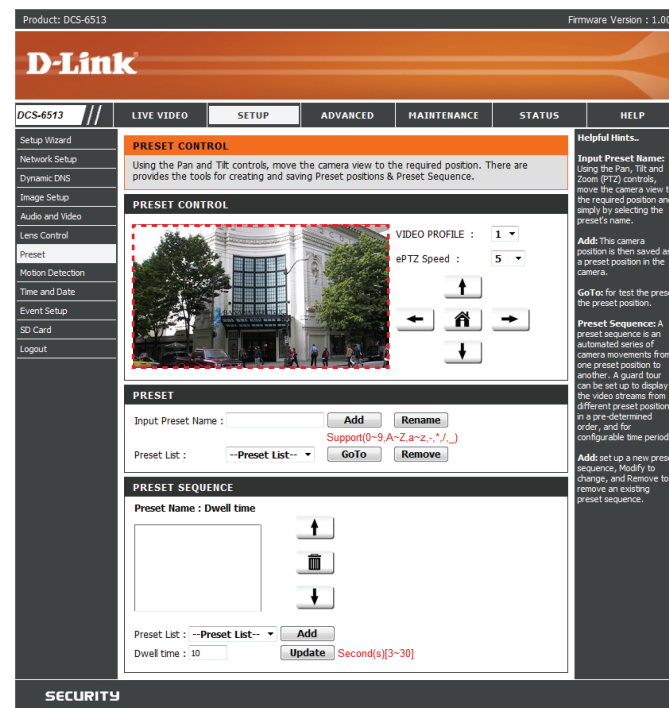

Motion Detection

Enabling Video Motion will allow your camera to use the motion detection feature. You may draw a finite motion area that will be used for monitoring. After making any changes, click the **Save Settings** button to save your changes.

Enable Video Motion: Select this box to enable the motion detection feature of your camera.

Sensitivity: Specifies the measurable difference between two sequential images that would indicate motion. Please enter a value between 0 and 100.

Percentage: Specifies the amount of motion in the window being monitored that is required to initiate an alert. If this is set to 100%, motion is detected within the whole window will trigger a snapshot.

Draw Motion Area: Draw the motion detection area by dragging your mouse in the window (indicated by the red square).

Erase Motion Area: To erase a motion detection area, simply click on the red square that you wish to remove.

Right clicking on the camera image brings up the following menu options:

Select All: Draws a motion detection area over the entire screen.

Clear All: Clears any motion detection areas that have been drawn.

Restore: Restores the previously specified motion detection areas.

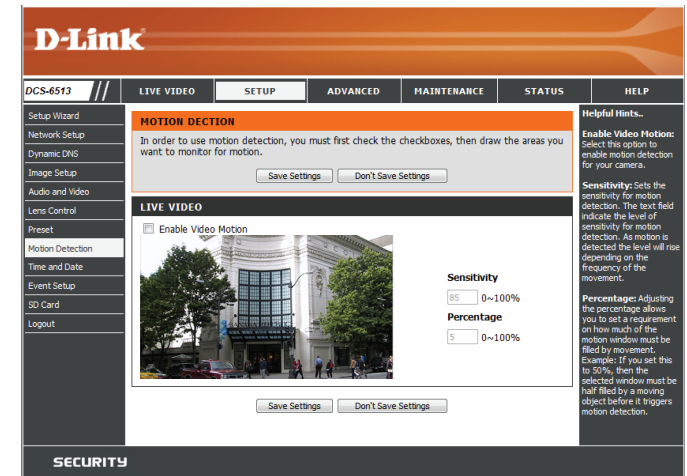

Time and Date

This section allows you to automatically or manually configure, update, and maintain the internal system clock for your camera. After making any changes, click the **Save Settings** button to save your changes.

Time Zone: Select your time zone from the drop-down menu.

Enable Daylight Saving: Select this to enable Daylight Saving Time.

Auto Daylight Saving: Select this option to allow your camera to configure the Daylight Saving settings automatically.

Set Date and Time Manually: Selecting this option allows you to configure the Daylight Saving date and time manually.

Offset: Sets the amount of time to be added or removed when Daylight Saving is enabled.

Synchronize with NTP Server: Enable this feature to obtain time automatically from an NTP server.

NTP Server: Network Time Protocol (NTP) synchronizes the DCS-6513 with an Internet time server. Choose the one that is closest to your location.

Set the Date and Time Manually: This option allows you to set the time and date manually.

Copy Your Computer's Time Settings: This will synchronize the time information from your PC.

Event Setup

In a typical application, when motion is detected, the DCS-6513 sends images to a FTP server or via e-mail as notifications. As shown in the illustration below, an event can be triggered by various sources, such as motion detection. When an event is triggered, a specified action will be performed. You can configure the Network Camera to send snapshots or videos to your e-mail address or FTP server.

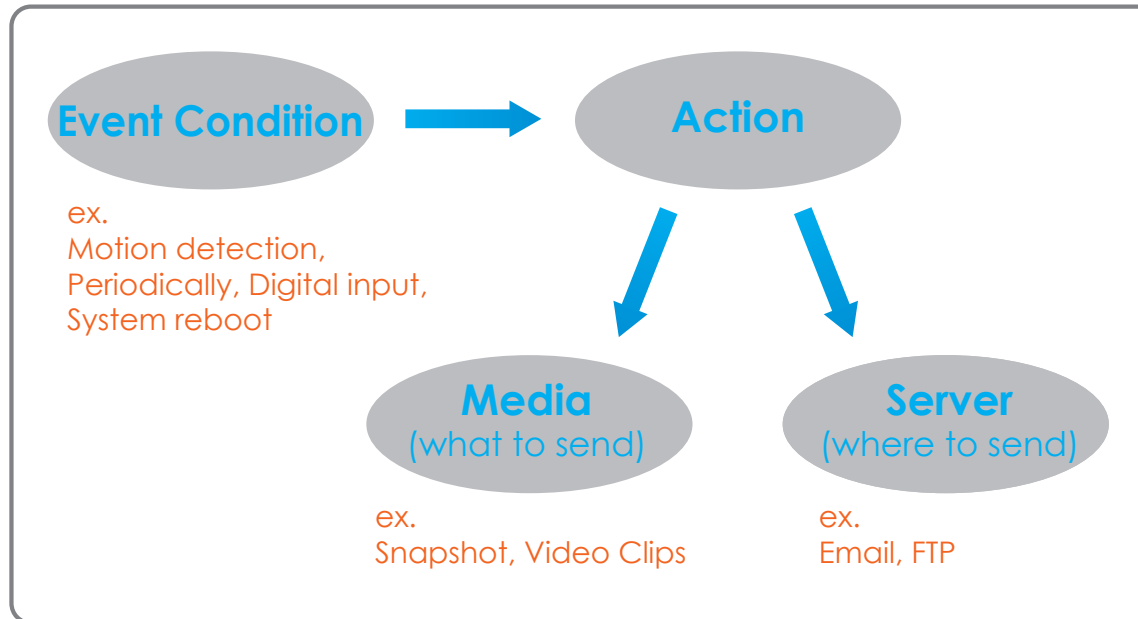

To start plotting an event, it is suggested to configure server and media columns first so that the Network Camera will know what action shall be performed when a trigger is activated.

The Event Setup page includes 4 different sections.

- Event
- Server
- Media
- Recording

1. To add a new item - "event, server or media," click **Add**. A screen will appear and allow you to update the fields accordingly.
2. To delete the selected item from the pull-down menu of event, server or media, click **Delete**.
3. Click on the item name to pop up a window for modifying.

D-Link

DCS-6513 // LIVE VIDEO SETUP ADVANCED MAINTENANCE STATUS HELP

Setup Wizard
Network Setup
Dynamic DNS
Image Setup
Audio and Video
Lens Control
Preset
Motion Detection
Time and Date
Event Setup
SD Card
Logout

EVENT SETUP

There are four sections in Event Setup page. They are event, server, media and recording. Click Add to pop a window to add a new item of event, server, media or recording. Click Delete to delete the selected item from event, server, media or recording. Click on the item name to pop a window to edit it. There can be at most 3 events and 2 recording. There can be at most 5 server and 5 media configurations.

SERVER

Name	Type	Address/Location
Add <input type="button" value="Delete"/>		

MEDIA

Media freespace: 6700KB

Name	Type	Source
Add <input type="button" value="Delete"/>		

EVENT

Name	Status	Sun	Mon	Tue	Wed	Thu	Fri	Sat	Time	Trigger
Add <input type="button" value="Delete"/>										

RECORDING

Name	Status	Sun	Mon	Tue	Wed	Thu	Fri	Sat	Time	Source	Destination
Add <input type="button" value="Delete"/>											

Helpful Hints..

Suggest setting server and media first before setting events. The servers and media which selected in event list are not be able to modify or delete. Please remove them first from the event if you want to delete or modify them. Recommend using different media in different event to make use all media be produced and received correctly. If using the same media in different events and the events trigger almost simultaneously, the servers in the second triggered event will not receive any media; there would be only notifications.

SECURITY

Add Server

You can configure up to 5 servers to save snapshots and/or video to. After making any changes, click the **Save Settings** button to save your changes.

Server Name: Enter the unique name of your server.

E-mail: Enter the configuration for the target e-mail server account.

FTP: Enter the configuration for the target FTP server account.

Network Storage: Specify a network storage device. Only one network storage device is supported.

SD Card: Use the camera's onboard SD card storage.

D-Link

DCS-6513 // LIVE VIDEO SETUP ADVANCED MAINTENANCE STATUS HELP

Setup Wizard
Network Setup
Dynamic DNS
Image Setup
Audio and Video
Lens Control
Preset
Motion Detection
Time and Date
Event Setup
SD Card
Logout

SERVER
You can set at most 5 different servers here for different event.

[Test] [Save Settings] [Don't Save Settings]

SERVER TYPE

Server Name:

Email

Sender email address
Recipient email address
Server address
User name
Password
Port
 This server requires a secure connection (Start TLS)

FTP

Server address
Port
User name
Password
Remote folder name
 Passive mode

Network storage

Network storage location
(for example: \\my_nas\disk\folder)
Workgroup
User name
Password
Primary WINS server

SD Card

[Test] [Save Settings] [Don't Save Settings]

Helpful Hints...

Server name The unique name for server. There are four kinds of servers supported. They are email server, FTP server, HTTP server and network storage.

Email server: "Sender email address" The email address of the sender. "Recipient email address" The email address of the recipient.

FTP server: "Remote folder name" Granted folder on the external FTP server. The string must conform to that of the external FTP server. Some FTP servers cannot accept a preceding slash symbol before the path without virtual path mapping. Refer to the instructions for the external FTP server for details. The folder privilege must be open for upload. "Passive Mode" Check it to enable passive mode in transmission.

Network storage: Only one network storage is supported. "Network storage location" The path to upload the media. "Workgroup" The workgroup for network storage.

SD card: Use the SD card for recording media.

Add Media

There are three types of media, **Snapshot**, **Video Clip**, and **System Log**. After making any changes, click the **Save Settings** button to save your changes.

Media Name: Enter a unique name for media type you want to create.

Snapshot: Select this option to set the media type to snapshots.

Source: Set the video profile to use as the media source. Refer to **Audio and Video** in "Audio and Video" on page 46 for more information on video profiles.

Send pre-event image(s) [0~4]: Set the number of pre-event images to take. Pre-event images are images taken before the main event snapshot is taken.

Send post-event image(s) [0~7]: Set the number of post-event images to take. Post-event images are images taken after the main event snapshot is taken.

For example:

If both the Send pre-event images and Send post-event images are set to four, a total of 9 images are generated after a trigger is activated.

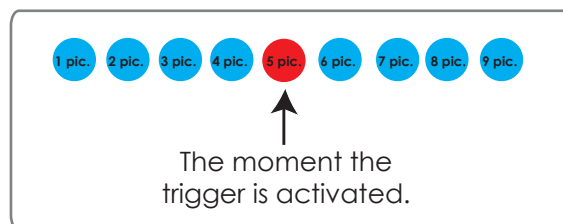

File name prefix: The prefix name will be added on the file name.

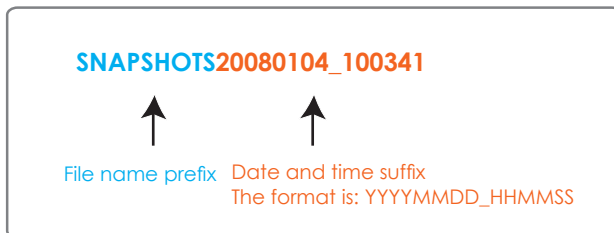

Add date and time suffix to file name: Check this to add timing information as file name suffix.

Video clip: Select this option to set the media type to video clips.

Source: Set the video profile to use as the media source. Refer to "Audio and Video" on page 46 for more information on video profiles.

Pre-event recording: This sets how many seconds to record before the main event video clip starts. You can record up to 4 seconds of pre-event video.

Maximum duration: Set the maximum length of video to record for your video clips.

Maximum file size: Set the maximum file size to record for your video clips.

System log: Select this option to set the media type to system logs. This will save the event to the camera system log, but will not record any snapshots or video.



Add Event

Create and schedule up to 3 events with their own settings here. After making any changes, click the **Save Settings** button to save your changes.

Event name: Enter a name for the event.

Enable this event: Select this box to activate this event.

Priority: Set the priority for this event. The event with higher priority will be executed first.

Delay: Select the delay time before checking the next event. It is being used for both events of motion detection and digital input trigger.

Trigger: Specify the input type that triggers the event.

Video Motion Detection: Motion is detected during live video monitoring. Select the windows that need to be monitored.

Periodic: The event is triggered in specified intervals. The trigger interval unit is in minutes.

Digital Input: The external trigger input to the camera.

System Boot: Triggers an event when the system boots up.

Network Lost: Triggers an event when the network connection is lost.

Time: Select **Always** or enter the time interval.

Server: Specify the location where the event information should be saved to.

Add Recording

Here you can configure and schedule the recording settings. After making any changes, click the **Save Settings** button to save your changes.

Recording entry name: The unique name of the entry.

Enable this recording: Select this to enable the recording function.

Priority: Set the priority for this entry. The entry with a higher priority value will be executed first.

Source: The source of the stream.

Recording schedule: Scheduling the recording entry.

Recording settings: Configuring the setting for the recording.

Destination: Select the folder where the recording file will be stored.

Total cycling recording size: Please input a HDD volume between 1MB and 2TB for recording space. The recording data will replace the oldest record when the total recording size exceeds this value. For example, if each recording file is 6MB, and the total cyclical recording size is 600MB, then the camera will record 100 files in the specified location (folder) and then will delete the oldest file and create new file for cyclical recording.

Please note that if the free HDD space is not enough, the recording will stop. Before you set up this option please make sure your HDD has enough space. It is advised not to save other files in the same folder as recording files.

The screenshot shows the D-Link DCS-6513 web interface. The top navigation bar includes 'LIVE VIDEO', 'SETUP', 'ADVANCED', 'MAINTENANCE', 'STATUS', and 'HELP'. The 'SETUP' tab is active, and the 'RECORDING' sub-tab is selected. The main content area is divided into three sections:

- RECORDING:** Contains a 'Recording entry name' text field, an 'Enable this recording' checkbox, a 'Priority' dropdown menu (set to 'normal'), and a 'Source' dropdown menu (set to 'Profile 1').
- RECORDING SCHEDULE:** Features a weekly schedule grid with checkboxes for Sun, Mon, Tue, Wed, Thu, Fri, and Sat. Below the grid is a 'Time' section with radio buttons for 'Always' and 'From' (with time range selectors for hours and minutes).
- RECORDING SETTINGS:** Includes a 'Destination' dropdown menu (set to 'None'), a 'Total cycling recording size' input field (set to 1000 Mbytes), a 'Size of each file for recording' dropdown (set to 10 Mbytes), and a 'Time of each file for recording' dropdown (set to 10 seconds). A 'File Name Prefix' text field is also present.

At the bottom of each section are 'Save Settings' and 'Don't Save Settings' buttons. A 'Helpful Hints' sidebar on the right provides additional information, including a note about enabling recording on a shared folder and a note about the 'Always' option.

Size of each file for recording: If this is selected, files will be separated based on the file size you specify.

Time of each file for recording: If this is selected, files will be separated based on the maximum length you specify.

File Name Prefix: The prefix name will be added on the file name of the recording file(s).

D-Link

DCS-6513 // LIVE VIDEO SETUP ADVANCED MAINTENANCE STATUS HELP

RECORDING
 You can setup schedule recording to network storage with your specify week day and time period.

RECORDING
 Recording entry name:
 Enable this recording
 Priority: normal
 Source: Profile 1

RECORDING SCHEDULE
 Sun Mon Tue Wed Thu Fri Sat
Time
 Always
 From 00:00 To 23:59

RECORDING SETTINGS
 Destination: None
 Total cycling recording size: 1000 Mbytes [200~2000000]
 Size of each file for recording: 10 Mbytes
 Time of each file for recording: 10 seconds
 File Name Prefix:

Helpful Hints...
Recording: Enable this option if you want to upload the recording to a shared folder on the network.
Recording schedule: Select the day(s) according to when you want the IP camera to make a video clip.
Always: This enables the IP camera to make video clips continuously.
From: The time range specified for the video clip.
Total cycling recording size: Please input the network path of your network storage, it will like "192.168.1.100/record". If the network storage need authentication, please enter your user name and password here.
Note: Please Format SD card before use. The entire data in the SD card will be erased after formatting.

SECURITY

SD Card

Here you may browse and manage the recorded files which are stored on the SD card.

Format SD Card: Click this icon to automatically format the SD card and create "picture" & "video" folders.

View Recorded Picture: If the picture files are stored on the SD card, click on the picture folder and choose the picture file you would like to view.

Playback Recorded Video: If video files are stored on the SD card, click on the video folder and choose the video file you would like to view.

Refresh: Reloads the file and folder information from the SD card.

The screenshot shows the D-Link DCS-6513 web interface. The main content area is titled "SD CARD" and contains the following information:

SD Card: / SD Status: Ready

Files per Page: 10 Refresh 1 of 1

Delete	File	Num of files	Size
<input type="checkbox"/>	dcm	0	
<input type="checkbox"/>	Video	0	
<input type="checkbox"/>	Picture	0	
<input type="checkbox"/>	2011_06_22 HALF at Lights out Day	1	
<input type="checkbox"/>	nkon001.dsc		1

Format SD Card Total:15981056KB, Used:7878368KB, Free:8102688KB

OK

The sidebar on the right contains "Helpful Hints..." with instructions for formatting the SD card and viewing recorded pictures and videos.

Advanced Digital Input/Output

This screen allows you to control the behavior of digital input and digital output devices. The I/O connector provides the physical interface for digital output (DO) and digital input (DI) that is used for connecting a variety of external alarm devices such as IR-Sensors and alarm relays. The digital input is used for connecting external alarm devices and once triggered images will be taken and e-mailed. After making any changes, click the **Save Settings** button to save your changes.

Select D/I or D/O Mode: The camera will send a signal when an event is triggered, depending upon the type of device connected to the DI circuit.

N.C. stands for **Normally Closed**. This means that the normal state of the circuit is closed. Therefore events are triggered when the device status changes to "Open."

N.O. stands for **Normally Open**. This means that the normal state of the circuit is open. Therefore events are triggered when the device status changes to "Closed."

Video Output: Enable/ disable the BNC terminal TV output signal.

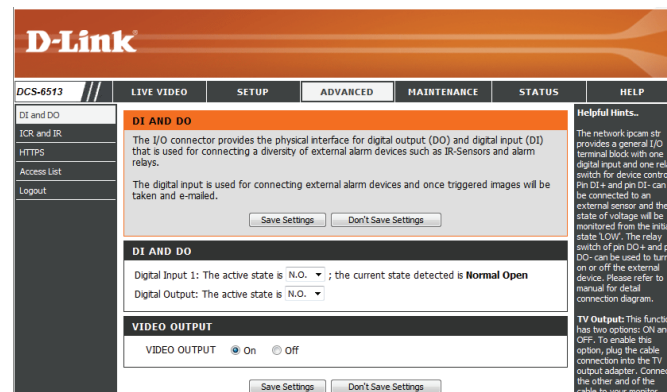

ICR and IR

Here you can configure the ICR and IR settings. An IR(Infrared) Cut-Removable (ICR) filter can be disengaged for increased sensitivity in low light environments.

Automatic: The Day/Night mode is set automatically. Generally, the camera uses Day mode and switches to Night mode when needed.

Day Mode: Day mode enables the IR Cut Filter.

Night Mode: Night mode disables the IR Cut Filter.

Schedule Mode: Set up the Day/Night mode using a schedule. The camera will enter Day mode at the starting time and return to Night mode at the ending time.

IR Light Control: The camera can enable or disable the IR (infrared) light according to your preferences. This setting provides additional controls depending on your specific application.

Off: The IR light will always be off.

On: The IR light will always be on.

Sync: The IR light will turn on when the ICR sensor is on.

Schedule: The IR light will turn on or off according to the schedule that you specify below.

D-Link

DCS-6513 // LIVE VIDEO SETUP ADVANCED MAINTENANCE STATUS HELP

DI and DO
ICR and IR
HTTPS
Access List
Logout

ICR AND IR

An IR(Infrared) Cut-Removable(ICR) filter can be disengaged from the image path for increased sensitivity in low light environments. The ICR filter will automatically engage depending on the ambient light, allowing the camera to be effective in day/night environments.
1. Select the Day/Night from the radio button. The available options are Automatic, Schedule mode, Day mode and Night mode.
2. The default value is Automatic.

Light Sensor Sensitivity
Light sensor sensitivity has Low, Medium, and High three different levels. You may get current camera light illumination by clicking Refresh button to set proper level of Light sensor sensitivity. For example, when level sets at High less than 30lux, camera will switch Day & Night mode to Night mode.

IR Light
The built-in IR light illuminators will be activated automatically or manually so as to supplement the low light situation without additional equipment.

Save Settings Don't Save Settings

ICR

Removable IR-Cut filter trigger condition:
 Automatic Sensitivity: Medium: <20Lux over 30 lux Refresh
 Day mode
 Night mode
 Schedule mode

Day mode(24hr)
From 07:00 To 18:00

IR LIGHT

IR Light Control Medium:20m
 Off
 On
 Sync. With ICR
 Schedule

IR Light Control On(24hr)
From 07:00 To 18:00

Save Settings Don't Save Settings

Helpful Hints...

Automatic: The day/Night mode is set automatically. It is normally set in the Day mode and changes to the Night mode in a dark place.

Day mode: The Day mode means enable the IR Cut Filter.

Night mode: The Night mode means enable the IR Cut Filter.

Schedule mode: Set the Day/Night mode using the schedule. Fill in the time so the Day/Night mode is normally set in Day mode and it enters the Day mode at the start time and returns to the Night mode at the end time.

IR Light Control: In poor light conditions, open IR Light Control to automatically turn on the light to enable you to take clear picture. The IR Light Control has 4 options: Off, On, Sync. with ICR, and Schedule. Off: This option disable the IR Light control. On: This option automatically opens the IR Light control to enable a camera to take clear images in poor light conditions. Sync. with ICR: In this option, the IR Light Control will open automatically and follow the ICR setting. Schedule: In this option, you have to customize the settings to set the time period you want. Please set the Start time and the End time of your chosen schedule.

SECURITY

HTTPS

This page allows you to install and activate an HTTPS certificate for secure access to your camera. After making any changes, click the **Save Settings** button to save your changes.

Enable HTTPS Secure Connection: Enable the HTTPS service.

Create Certificate Method: Choose the way the certificate should be created. Three options are available:

- Create a self-signed certificate automatically
- Create a self-signed certificate manually
- Create a certificate request and install

Status: Displays the status of the certificate.

Note: The certificate cannot be removed while the HTTPS is still enabled. To remove the certificate, you must first uncheck **Enable HTTPS secure connection**.

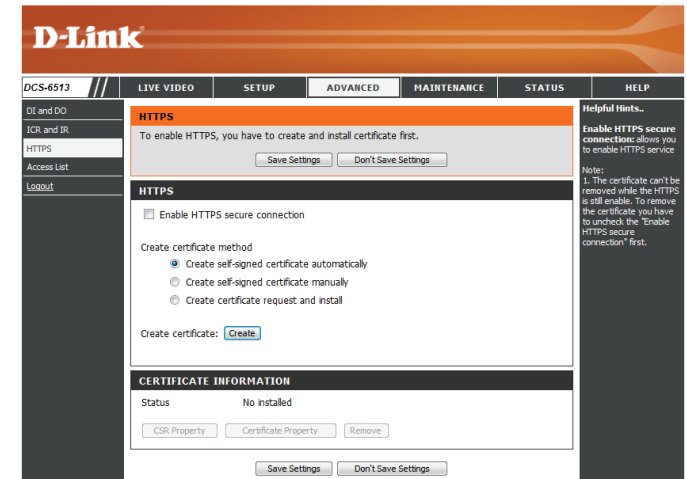

Access List

Here you can set access permissions for users to view your DCS-6513.

Allow list: The list of IP addresses that have the access right to the camera.

Start IP address: The starting IP Address of the devices (such as a computer) that have permission to access the video of the camera. Click **Add** to save the changes made.

Note: A total of seven lists can be configured for both columns.

End IP address: The ending IP Address of the devices (such as a computer) that have permission to access the video of the camera.

Delete allow list: Remove the customized setting from the Allow List.

Deny list: The list of IP addresses that have no access rights to the camera.

Delete deny list: Remove the customized setting from the Delete List.

For example:

When the range of the Allowed List is set from 1.1.1.0 to 192.255.255.255 and the range of the Denied List is set from 1.1.1.0 to 170.255.255.255. Only users with IPs located between 171.0.0.0 and 192.255.255.255 can access the Network Camera.

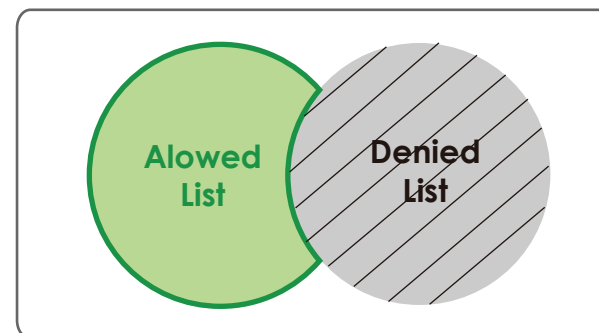
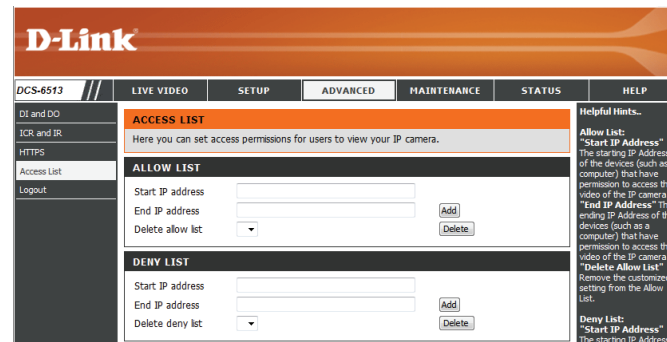

Maintenance

Device Management

You may modify the name and administrator's password of your camera, as well as add and manage the user accounts for accessing the camera. You may also use this section to create a unique name and configure the OSD settings for your camera.

Admin Password Setting: Set a new password for the administrator's account.

Add User Account: Add new user account.

User Name: The user name for the new account.

Password: The password for the new account.

User List: All the existing user accounts will be displayed here. You may delete accounts included in the list, but you may want to reserve at least one as a guest account.

Camera Name: Create a unique name for your camera that will be added to the file name prefix when creating a snapshot or a video clip.

Enable OSD: Select this option to enable the On-Screen Display feature for your camera.

Label: Enter a label for the camera, which will be shown on the OSD when it is enabled.

Show Time: Select this option to enable the time-stamp display on the video screen.

D-Link

DCS-6513 // LIVE VIDEO SETUP ADVANCED MAINTENANCE STATUS HELP

ADMIN

Here you can change the administrator's password for your IP camera as well as add and/or delete user account(s). You can configure the information, such as IP camera's name and time via this page. You can also enable the OSD (On-Screen Display) feature in order to display the IP camera name and time stamp for your video recordings.

ADMIN PASSWORD SETTING

New Password 63 characters maximum
Retype Password

ADD USER ACCOUNT

User Name 20 users maximum
New Password 63 characters maximum
Retype Password

USER LIST

User Name -- User list --

DEVICE SETTING

IP camera Name DCS-6513 63 characters maximum
 Enable OSD
Label DCS-6513 63 characters maximum
Show time

LED

LED On Off

Helpful Hints.

Enabling OSD, the IP camera name and time will be displayed on the video screen for the user.

For security purposes, it is recommended that you change the password for your administrator account. Be sure to write down the new password to avoid having to reset the IP camera in the event that it is forgotten.

LED: In the near panel of your camera there is a LED beside the network adapter. On: The LED will flash a light to indicate if the network is working or not. Off: No light will show, forth option is turn off.

SECURITY

Copyright © 2012 D-Link Corporation.

System

In this section, you may backup, restore and reset the camera configuration, or reboot the camera.

Save To Local Hard Drive: You may save your current camera configuration as a file on your computer.

Load From Local Hard Drive: Locate a pre-saved configuration by clicking **Browse** and then restore the pre-defined settings to your camera by clicking **Load Configuration**.

Restore to Factory Default: You may reset your camera and restore the factory settings by clicking **Restore Factory Defaults**.

Reboot Device: This will restart your camera.

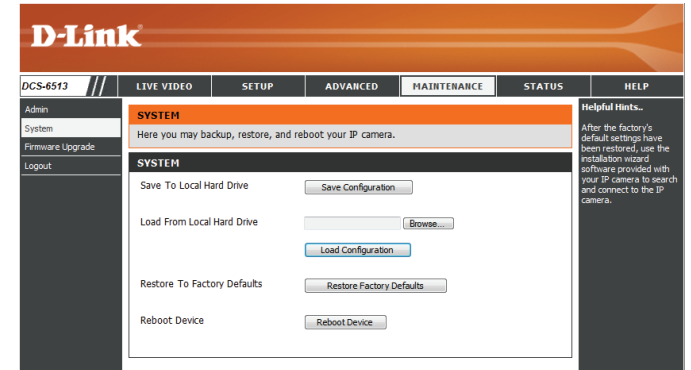

Firmware Upgrade

The camera's current firmware version will be displayed on this screen. You may visit the D-Link Support Website to check for the latest available firmware version.

To upgrade the firmware on your DCS-6513, please download and save the latest firmware version from the D-Link Support Page to your local hard drive. Locate the file on your local hard drive by clicking the **Browse** button. Select the file and click the **Upload** button to start upgrading the firmware.

Current Firmware Version: Displays the detected firmware version.

Current Product Name: Displays the camera model name.

File Path: Locate the file (upgraded firmware) on your hard drive by clicking **Browse**.

Upload: Uploads the new firmware to your camera.

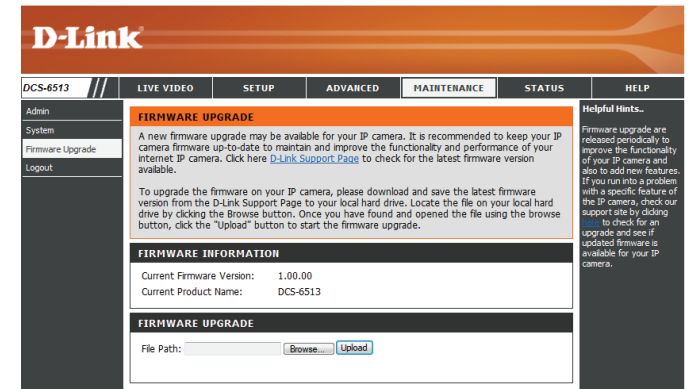

Status

Device Info

This page displays detailed information about your device and network connection.

The screenshot shows the D-Link web interface for the DCS-6513 device. The top navigation bar includes links for LIVE VIDEO, SETUP, ADVANCED, MAINTENANCE, STATUS (selected), and HELP. The left sidebar contains links for Device Info (selected), Log, and Logout. The main content area is titled "DEVICE INFO" and contains a message: "All of your network connection details are displayed on this page. The firmware version is also displayed here." Below this is an "INFORMATION" table with the following data:

INFORMATION	
IP camera Name	DCS-6513
Time & Date	Mon Jan 2 00:41:18 2012
Firmware Version	1.00.00
MAC Address	28:10:7B:06:CA:32
IP Address	192.168.0.111
IP Subnet Mask	255.255.255.0
Default Gateway	192.168.0.1
Primary DNS	192.168.0.1
Secondary DNS	0.0.0.0
PPPoE	Disable
DDNS	Disable
TV Output Mode	NTSC

On the right side, there is a "Helpful Hints.." section with the text: "This page displays all the information about the IP camera and network settings."

Logs

This page displays the log information of your camera. You may download the information by clicking **Download**. You may also click **Clear** to delete the saved log information.

D-Link

DCS-6513 // LIVE VIDEO SETUP ADVANCED MAINTENANCE STATUS HELP

Device Info
Log
Logout

SYSTEM LOG

The system log records IP camera events that have occurred.

CURRENT LOG

1. 2012-01-02 00:39:56 admin LOGIN OK FROM 192.168.0.110
2. 2012-01-02 00:39:48 admin LOGOUT FROM 192.168.0.110
3. 2012-01-02 00:32:37 admin FROM 192.168.0.110 TURN ON MASK AREA 2
4. 2012-01-02 00:32:37 admin FROM 192.168.0.110 TURN ON MASK AREA 3
5. 2012-01-02 00:32:37 admin FROM 192.168.0.110 TURN ON MASK AREA 1
6. 2012-01-02 00:32:12 admin LOGIN OK FROM 192.168.0.110
7. 2012-01-02 00:31:55 admin LOGOUT FROM 192.168.0.110
8. 2012-01-02 00:30:29 admin LOGIN OK FROM 192.168.0.110
9. 2012-01-02 00:30:25 admin LOGOUT FROM 192.168.0.110
10. 2012-01-02 00:27:24 admin LOGIN OK FROM 192.168.0.110
11. 2012-01-01 23:56:04 admin FROM 192.168.0.110 TURN OFF FLIP
12. 2012-01-01 23:56:02 admin FROM 192.168.0.110 TURN ON FLIP
13. 2012-01-01 23:08:44 admin FROM 192.168.0.110 SET AWB Auto
14. 2012-01-01 23:08:42 admin FROM 192.168.0.110 SET EXPOSURE TIME Low_noise
15. 2012-01-01 23:08:40 admin FROM 192.168.0.110 SET AWB Outdoor
16. 2012-01-01 23:08:36 admin FROM 192.168.0.110 SET AWB Indoor
17. 2012-01-01 23:08:32 admin FROM 192.168.0.110 SET AWB Fluorescent
18. 2012-01-01 23:04:35 admin LOGIN OK FROM 192.168.0.110
19. 2012-01-01 21:30:49 admin FROM 192.168.0.110 TURN OFF FLIP
20. 2012-01-01 21:30:45 admin FROM 192.168.0.110 TURN ON FLIP

First Page Previous 20 Next 20

Clear Download

Helpful Hints..

You can save the log to your local hard IP camera by clicking the Download button, and you can clear the log by clicking on the Clear button.

Help

This page provides helpful information regarding camera operation.

The screenshot shows the D-Link DCS-6513 web interface. At the top is the D-Link logo. Below it is a navigation bar with tabs for LIVE VIDEO, SETUP, ADVANCED, MAINTENANCE, STATUS, and HELP. The HELP tab is selected. On the left side, there is a sidebar with 'Help' and 'Logout' links. The main content area is titled 'HELP' and contains a list of links for each menu item: LIVE VIDEO (Camera), SETUP (Setup Wizard, Network Setup, Dynamic DNS, Image Setup, Audio and Video, Lens Control, Preset, Motion Detection, Time and Date, Event Setup, SD Card), ADVANCED (DI and DO, ICR and IR, HTTPS, Access List), MAINTENANCE (Admin, System, Firmware Upgrade), and STATUS (Device Info, Log). At the bottom of the page, there is a 'SECURITY' section and a copyright notice: Copyright © 2012 D-Link Corporation.

DCS-6513	LIVE VIDEO	SETUP	ADVANCED	MAINTENANCE	STATUS	HELP
Help Logout	HELP <ul style="list-style-type: none">LIVE VIDEOSETUPMAINTENANCEADVANCEDSTATUS	LIVE VIDEO <ul style="list-style-type: none">Camera	SETUP <ul style="list-style-type: none">Setup WizardNetwork SetupDynamic DNSImage SetupAudio and VideoLens ControlPresetMotion DetectionTime and DateEvent SetupSD Card	ADVANCED <ul style="list-style-type: none">DI and DOICR and IRHTTPSAccess List	MAINTENANCE <ul style="list-style-type: none">AdminSystemFirmware Upgrade	STATUS <ul style="list-style-type: none">Device InfoLog

SECURITY

Copyright © 2012 D-Link Corporation.

DI/DO Specifications

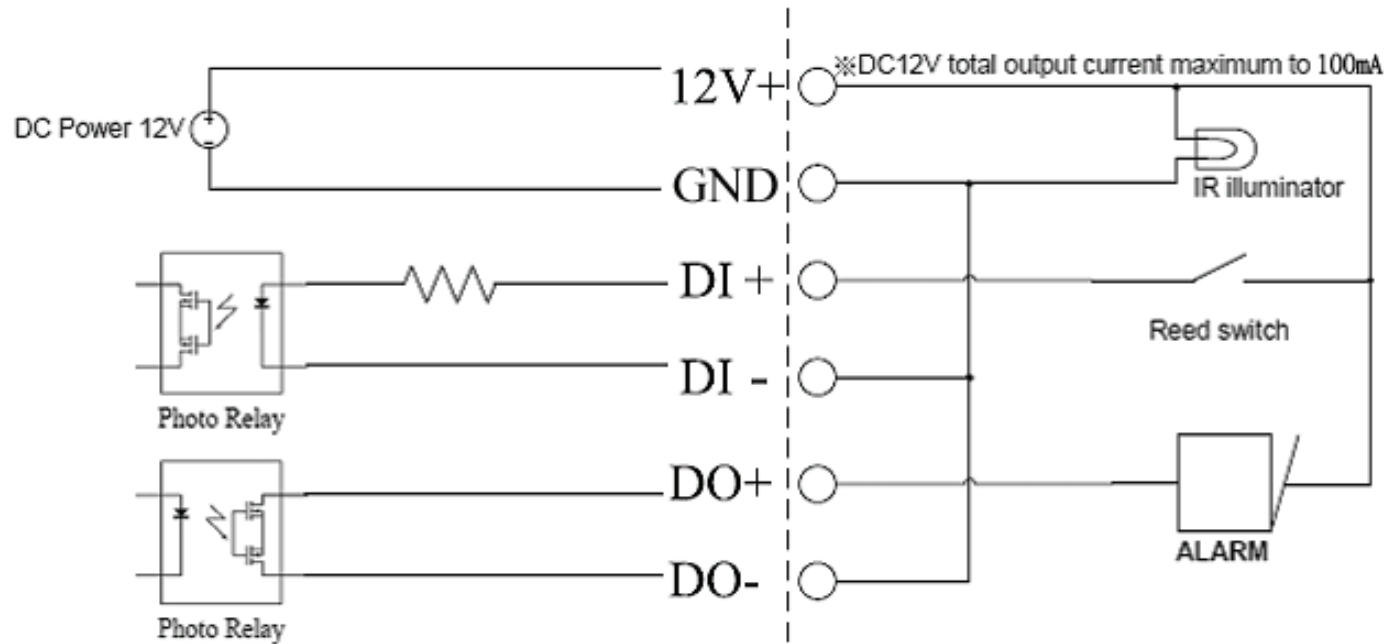

Technical Specifications

Camera	Camera Hardware Profile	<ul style="list-style-type: none"> ▪ 1/2.8" 3 Megapixel progressive CMOS sensor ▪ 20 meter IR illumination distance ▪ Minimum illumination 0 Lux with IR LED on ▪ Built-in Infrared-Cut Removable (ICR) Filter module ▪ 10x digital zoom 	<ul style="list-style-type: none"> ▪ 3~9mm vari focal lens ▪ Aperture F=1.2~2.3 ▪ Angle of view (16:9) <ul style="list-style-type: none"> ▪ -(H) 96.4° ~ 31.6° ▪ -(V) 51.2° ~ 17.7° ▪ -(D) 114.1° ~ 36.3°
	Camera Housing	IP67 compliant weatherproof housing	IK-10 vandal-proof compliant
	Image Features	<ul style="list-style-type: none"> ▪ Configurable image size, quality, frame rate, and bit rate ▪ Time stamp and text overlays ▪ Configurable motion detection windows 	<ul style="list-style-type: none"> ▪ Configurable privacy mask zones ▪ Configurable shutter speed, brightness, saturation, contrast, contrast, sharpness, zoom, focus, and aperture.
	Video Compression	<ul style="list-style-type: none"> ▪ Simultaneous H.264/MPEG-4/MJPEG format compression ▪ H.264/MPEG-4 multicast streaming 	<ul style="list-style-type: none"> ▪ JPEG for still images
	Video Resolution	16:9 - 1920 x 1080, 1280 x 720, 800 x 450, 640 x 360, 480 x 270, 320 x 176, 176 x 144 up to 30 fps.	4:3 - 2048x1536(@15fps), 1600x1200, 1024x768, 800x600, 640x480, 480x360, 320x240, 176x144@ 30fps
	Audio Support	G.726	G.711
	External Device Interface	<ul style="list-style-type: none"> ▪ 10/100 BASE-TX Ethernet port with PoE ▪ 1 DI / 1 DO ▪ DC12 V, 100 mA Output 	<ul style="list-style-type: none"> ▪ Micro SD/SDHC ▪ Audio input / output ▪ DI/DO connector 12 V DC output
Network	Network Protocols	<ul style="list-style-type: none"> ▪ IPv6 ▪ IPv4 ▪ TCP/IP ▪ UDP ▪ ICMP ▪ DHCP client ▪ NTP client (D-Link) ▪ DNS client ▪ DDNS client (D-Link) ▪ SMTP client ▪ FTP client 	<ul style="list-style-type: none"> ▪ HTTP / HTTPS ▪ Samba client ▪ PPPoE ▪ UPnP port forwarding ▪ RTP / RTSP/ RTCP ▪ IP filtering ▪ QoS ▪ CoS ▪ Multicast ▪ ONVIF compliant
	Security	Administrator and user group protection Password authentication	HTTP and RTSP digest encryption

Appendix A: Technical Specifications

System Management	System Requirements for Web Interface	<ul style="list-style-type: none"> ▪ Browser: Internet Explorer, Firefox, Chrome, or Safari 	
	Event Management	<ul style="list-style-type: none"> ▪ Motion detection ▪ Event notification and uploading of snapshots/video clips via e-mail or FTP 	<ul style="list-style-type: none"> ▪ Supports multiple SMTP and FTP servers ▪ Multiple event notifications ▪ Multiple recording methods for easy backup
	Remote Management	<ul style="list-style-type: none"> ▪ Take snapshots/video clips and save to local hard drive or NAS via web browser 	<ul style="list-style-type: none"> ▪ Configuration interface accessible via web browser
	OS Support	Windows 7/Vista/XP/2000	
	D-ViewCam™ System Requirements	<ul style="list-style-type: none"> ▪ Operating System: Microsoft Windows 7/Vista/XP ▪ Web Browser: Internet Explorer 7 or higher 	<ul style="list-style-type: none"> ▪ Protocol: Standard TCP/IP
	D-ViewCam™ Software Functions	<ul style="list-style-type: none"> ▪ Remote management/control of up to 32 cameras ▪ Viewing of up to 32 cameras on one screen 	<ul style="list-style-type: none"> ▪ Supports all management functions provided in web interface ▪ Scheduled event triggered or manual recording options
General	Weight	1.53kg (with Weather Shield)	
	External Power Adapter	Input: 100 to 240 V AC, 50/60 Hz	Output: 12 V DC 1.25 A
	Power Consumption	10.5 +-5% Watt	
	Temperature	Operating: -40 to 50 °C (-40 to 122 °F)	Storage: -20° to 70° C (-4° to 158° F)
	Humidity	Operating: 20% to 80% non-condensing	Storage: 5% to 95% non-condensing
	Certifications	CE CE LVD	FCC C-Tick
Optional Accessories		DCS-34-2 Pendant Mount	DCS-34-3 Bent Arm Mount

Dimensions

